

THE CONTENTS OF THIS DRAWING ARE THE EXCLUSIVE PROPERTY OF THE TECHNICAL MATERIEL CORP. ITS UNAUTHORIZED USE OR REPRODUCTION IN WHOLE OR IN PART IS STRICTLY FORBIDDEN.

REQ. PER UNIT

USED ON

MODEL

ASS'Y. NO.

DATE

GPT200K

AX-398

7-7-62

LD-1155 0

MARK TMC NO LD-1155-0/MS-3032-0 ON INSIDE.

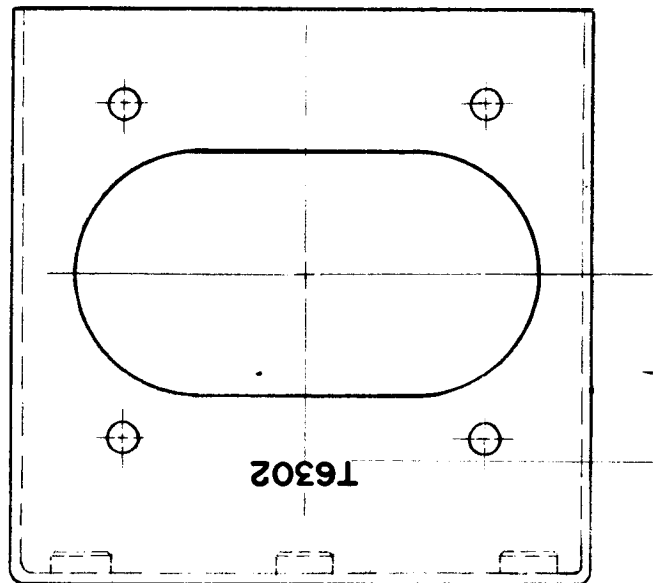
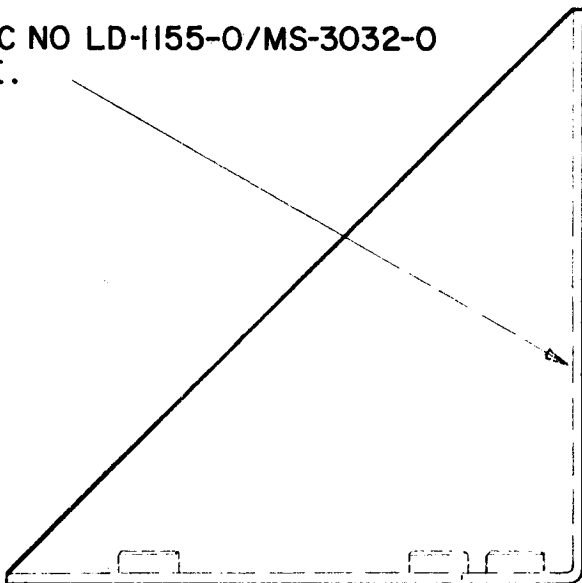

MARKING PROCESS:

AS PER TMC SPECIFICATION S-727.

LETTERING: 1/8 HIGH, BLACK GOTHIC, LOCATED AS SHOWN REF-TMC DWG. MS-3032

							REQ.	ITEM	PART NO.	F. BUDETTI	DESCRIPTION	SYMBOL	
							STOCK SIZE			THE TECHNICAL MATERIEL CORP. MAMARONECK, NEW YORK			
							MATERIAL			MARKING, XMFR MTG. BRACKET			
							TYPE & TEMPER			MARKING METHOD: AS PER TMC SPEC. S-727			
							HEAT TREAT. SPEC.			John C. Diele <i>JCD</i> <i>RAC</i>			
UNLESS OTHERWISE SPECIFIED: DIMENSIONS ARE IN INCHES TOLERANCES ON FRAC. ± 1/64 DEC. ± .5 ANGLES ± 1/2°							SCALE: 1:1			DRAWN <i>JCD</i> CHECKED <i>JCB</i> FINAL APPROVAL			
MAXIMUM ALLOWABLE TOLERANCES HAVE BEEN DETERMINED AND ANY DEVIATIONS WILL BE CAUSE FOR REJECTION. REMOVE ALL BURRS AND SHARP EDGES							FINISH & SPEC. NO.			LD-1155 0			