

REVISIONS					
SYM	DESCRIPTION	DATE	E.M.N. NO.	DRAFT	CHKD APPD
X	EXPERIMENTAL RELEASE	3.10.64			
O	ORIGINAL RELEASE FOR PRODUCTION	3.11.64			
A	ON DETAIL "A" WAS 40 REQ.	8.17.64	12130	WJB	
B	PJ339 WAS PJ-399	1.31.66	15585	HLA	

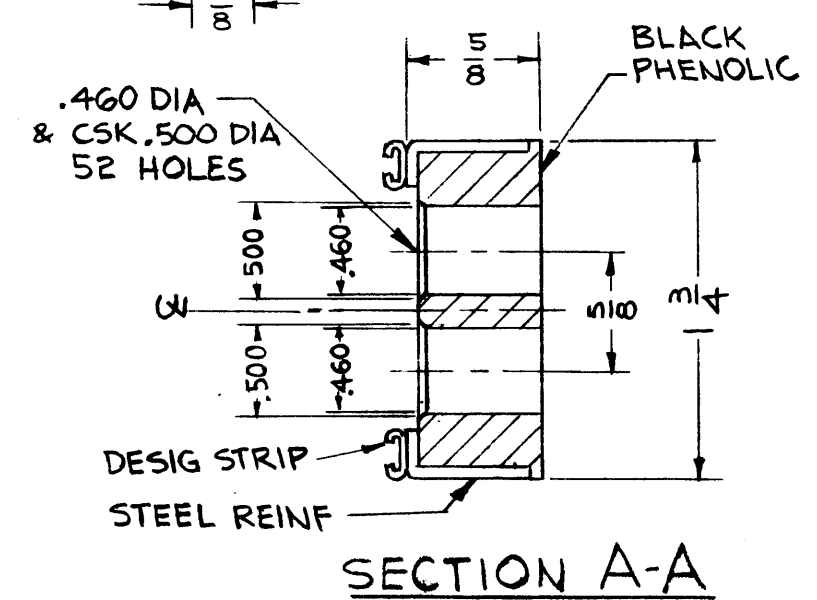
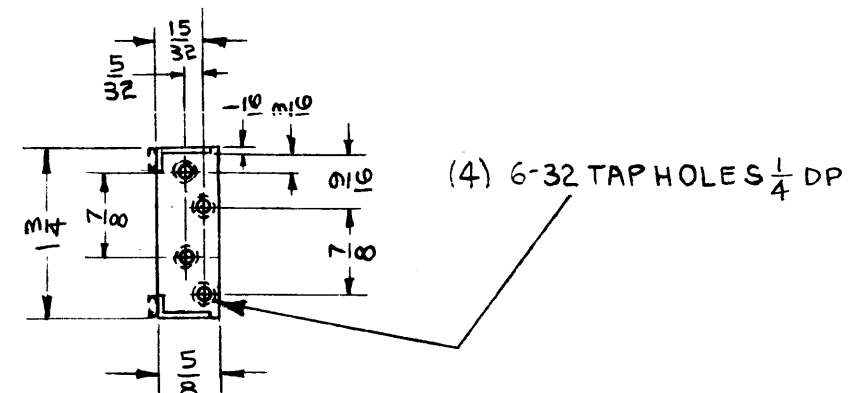
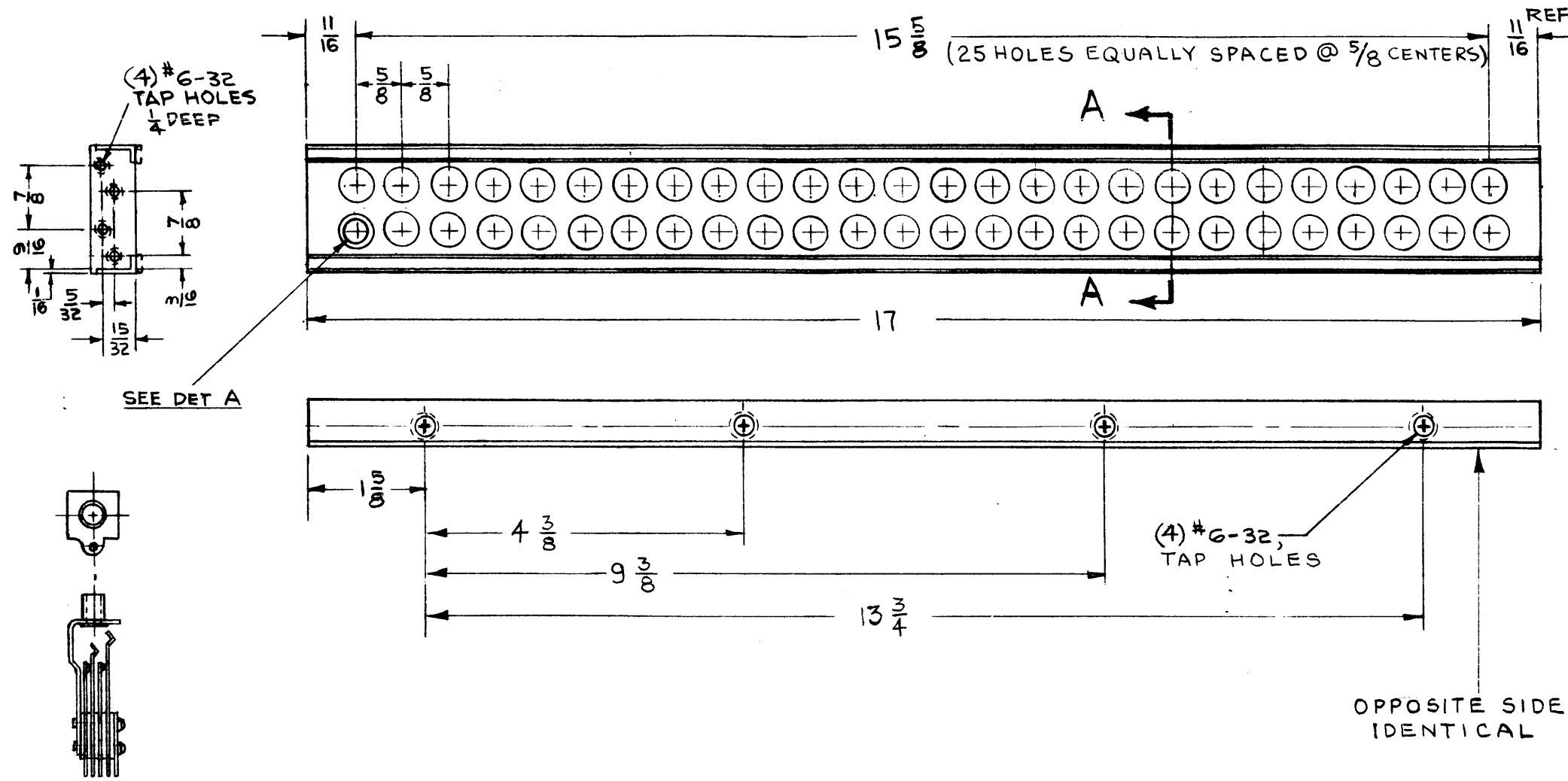

DETAIL A
PJ339
38 REQD

(MODIFIED PERTMC REQUIREMENTS)

REQ'D.	ITEM	PART NUMBER	DESCRIPTION	SYMBOL
I. JOHNSON LIST OF MATERIAL				
MATERIAL			THE TECHNICAL MATERIEL CORP. MAMARONECK, NEW YORK	
FINISH			TITLE PANEL, JACK LPP-4	
UNLESS OTHERWISE SPECIFIED DIMENSIONS ARE IN INCHES AND INCLUDE CHEMICALLY APPLIED OR PLATED FINISHES			DRAWN: WJB CHECKED: @ ELECT. DES.: JJ MECH. DES.: JJ	DATE: 10-30-63 DATE: 3-10-64 DATE: 3-10-64 DATE: 3-10-64
DECIMALS .X ± .05 .XX ± .01 .XXX ± .005			TOLERANCES ± 1/64 ANGLES ± 0° 30'	FINAL APPROVAL: RAL DATE: 2/1/64 SHEET: JJ-304 REV. LTR.: B

Q'TY./UNIT	MODEL USED ON	ASS'Y. NO.
1	LPP-4	
SCALE	CODE	
NONE	C	S-401-123(PJ-390)

NOTES

THE CONTENTS OF THIS DRAWING ARE THE EXCLUSIVE PROPERTY OF THE TECHNICAL MATERIEL CORP. ITS UNAUTHORIZED USE OR REPRODUCTION IN WHOLE OR IN PART IS STRICTLY FORBIDDEN.