

JJ-213 B

THE CONTENTS OF THIS DRAWING ARE THE EXCLUSIVE PROPERTY OF THE TECHNICAL MATERIEL CORP. ITS UNAUTHORIZED USE OR REPRODUCTION IN WHOLE OR IN PART IS STRICTLY FORBIDDEN.

SPECIFICATIONS

SERIES ~ QDS  
 NO. OF CONTACTS ~ ONE (1)  
 TYPE OF CONTACT ~ FEMALE  
 DIELECTRIC ~ TEFLON

ELECTRICAL DATA

MAX. PEAK VOLTAGE ~ 500  
 FREQ. LIMIT ~ 10,000  
 NOMINAL IMPEDANCE ~ 50 Ω

MATING ACCOMODATIONS

TYPE ~ BNC  
 MAX. O.D. ~  
 IMPEDANCE ~ 50 Ω

MATERIAL

HARDWARE ~ BRASS  
 EXTERNAL PARTS ~ BRASS  
 CONTACT ~ BERYLLIUM  
FINISH  
 EXTERNAL PARTS ~ SILVER PLATE & RHODIUM FLASH,  
 CONTACT ~ SILVER PLATE & GOLD FLASH.  
 HARDWARE - SILVER PLATE & RHODIUM FLASH,

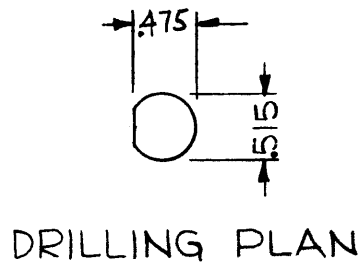
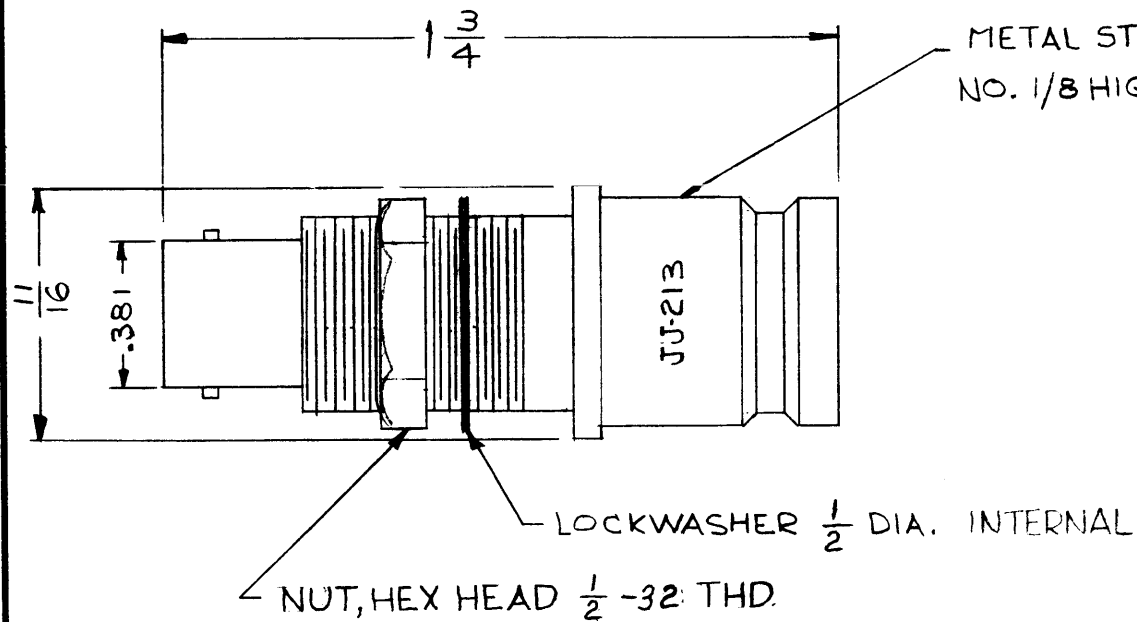

SYM	DESCRIPTION	DATE	CH. NO.	DRAFTS	CHECKER	ENG. APP.
B	LOCKWASHER WAS 3/4; NUT WAS 3/4-20	2-10-64	10832	AM.	T.R	<i>[Signature]</i>
A	SPECS. ADDED; 11/16 DIM. WAS 11/32	5-4-62		EE		

UNLESS OTHERWISE SPECIFIED:  
 DIMENSIONS ARE IN INCHES  
 TOLERANCES ON FRACTIONS ± 1/64 DECIMALS ± .005 ANGLES ± 1/2°

SCALE: S-401-70(2272)

MAXIMUM ALLOWABLE TOLERANCES HAVE BEEN DETERMINED AND ANY DEVIATIONS WILL BE CAUSE FOR REJECTION.  
 REMOVE ALL BURRS AND SHARP EDGES

REQ. PER UNIT	MODEL	SECTION	ASS'Y. NO.	DATE
				4-24-62
USED ON				

REQ.	ITEM	PART NO.	PRITCHARD DESCRIPTION	SYMBOL
		SS	THE TECHNICAL MATERIEL CORP. MAMARONECK, NEW YORK	
		SS	ADAPTOR, CONNECTOR RECEPTACLE - QDS TO BNC	
			G. SENCEN	<i>[Signature]</i>
			TYPE & TEMPER	CHECKED
			HEAT TREAT. SPEC.	FINAL APPROVAL
			FINISH & SPEC. NO.	JJ-213 B
			ELEC. DES. APP.	MECH. DES. APP.