

JJ119-1

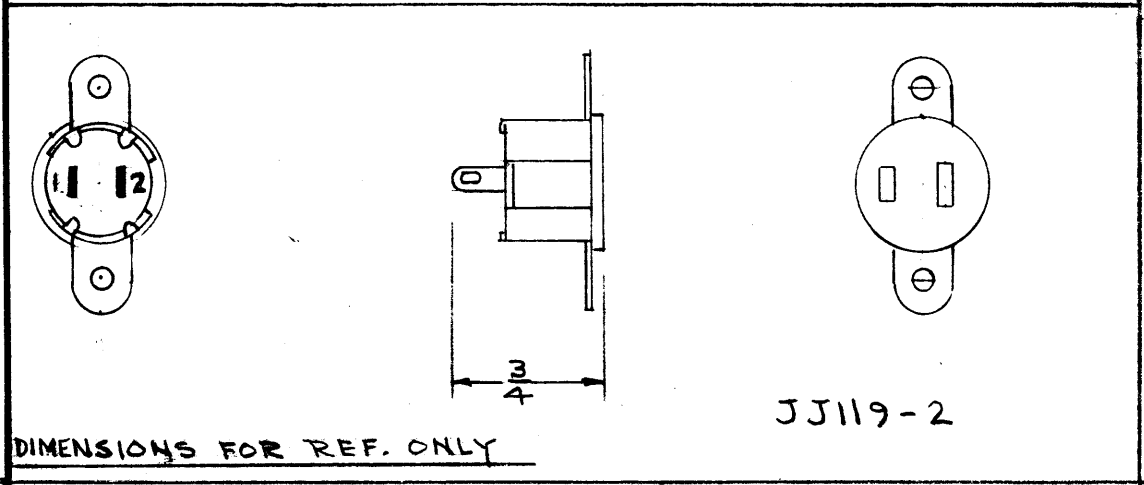

JJ119-2

DIMENSIONS FOR REF. ONLY

	A	B
JJ119-1,-2	31/64	31/32
JJ119-3,-4	1/2	1

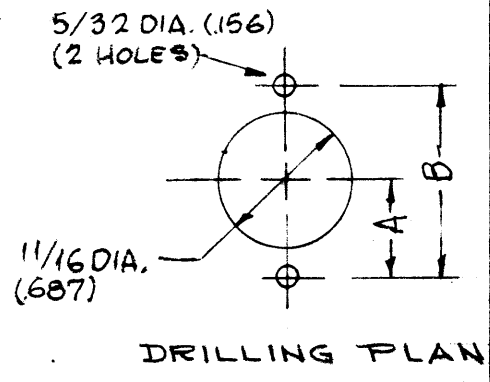

DRILLING PLAN

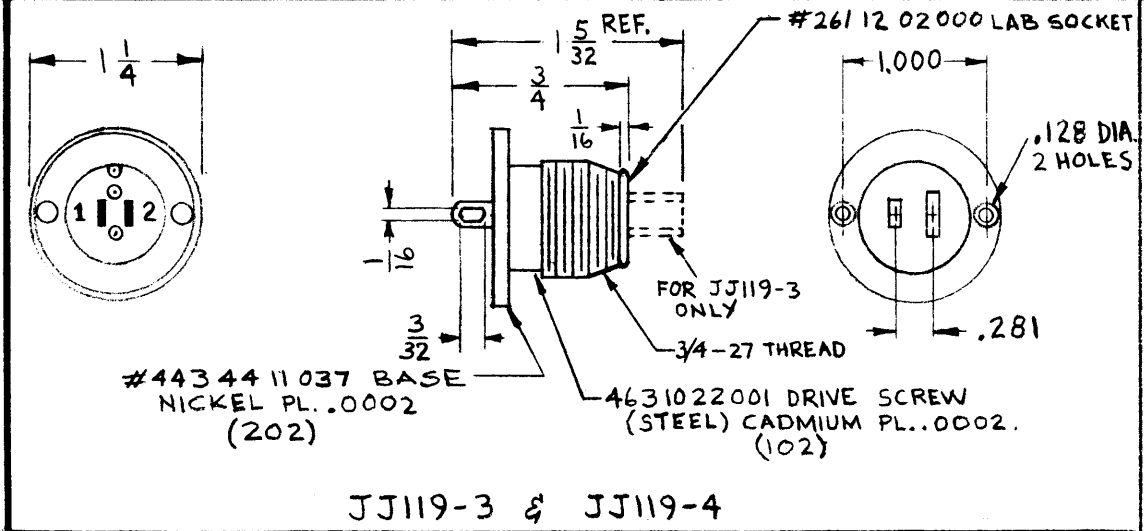

JJ119-3 & JJ119-4

#44344 11037 BASE NICKEL PL..0002 (202)
 #26112 02000 LAB SOCKET
 4631022001 DRIVE SCREW (STEEL) CADMIUM PL..0002. (102)

B
JJ119

REVISIONS						
SYM	DESCRIPTION	DATE	E.M.N. NO.	DRAFT	CHKD	APPD
B	REDRAWN FROM #1 SIZE; JJ119-3 & (-4) ADDED; ON CHART: "MFG. P/N" WAS "CINCH"; MATES WITH COL. ADD; * NOTE ADDED; S401 #ADD; "REF: CINCH MFG. CORP." DELE.	4-5-65	13806	2L	JCB	

TMC NO.	MFG. P/N	TYPE	MATES WITH
* JJ119-1	P-302-AB	MALE	PL105-2
* JJ119-2	3-302-AB	FEMALE	PL105-1
JJ119-3	P202 B	MALE	PL105-3
JJ119-4	S202 B	FEMALE	PL105-4

* DO NOT USE JJ119-1 & JJ119-2 IN NEW DESIGN

NOTES

Q'TY./UNIT	MODEL USED ON	ASS'Y. NO.
SCALE	CODE	S401-176

THE CONTENTS OF THIS DRAWING ARE THE EXCLUSIVE PROPERTY OF THE TECHNICAL MATERIEL CORP. ITS UNAUTHORIZED USE OR REPRODUCTION IN WHOLE OR IN PART IS STRICTLY FORBIDDEN.

REQ'D.	ITEM	PART NUMBER	DESCRIPTION	SYMBOL
LIST OF MATERIAL				
MATERIAL		THE TECHNICAL MATERIEL CORP. MAMARONECK, NEW YORK		
FINISH		RECEPTACLE 2 PRONG		
UNLESS OTHERWISE SPECIFIED DIMENSIONS ARE IN INCHES AND INCLUDE CHEMICALLY APPLIED OR PLATED FINISHES		DRAWN <i>S. Savana</i>	DATE 4/5/65	FINAL APPROV. <i>M. Howe</i>
		CHECKED	DATE	DATE 4/27/65
DECIMALS .X ± .05 .XX ± .01 .XXX ± .005		ELECT. DES.		DATE
FRACTIONS ± 1/64 ANGLES ± 0° 30'		MECH. DES. <i>JH</i>		DATE 4/22/65
				SHEET
				REV. LTR. B