

IF IT IS FOUND DESIRABLE TO CHANGE ANY TOLERANCE OR OTHER DETAIL SPECIFIED ON THIS DRAWING NOTIFY THE PURCHASER PROMPTLY.

STANDARD DRAWING

JJ-024

MAXIMUM ALLOWABLE TOLERANCES HAVE BEEN DETERMINED AND DEVIATIONS WILL BE CAUSE FOR REJECTION. REMOVE ALL BURRS AND SHARP EDGES

USED ON

MODEL

PROJECT NO.

ASS'Y. NO.

DATE

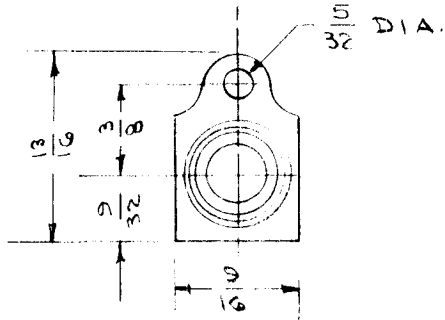
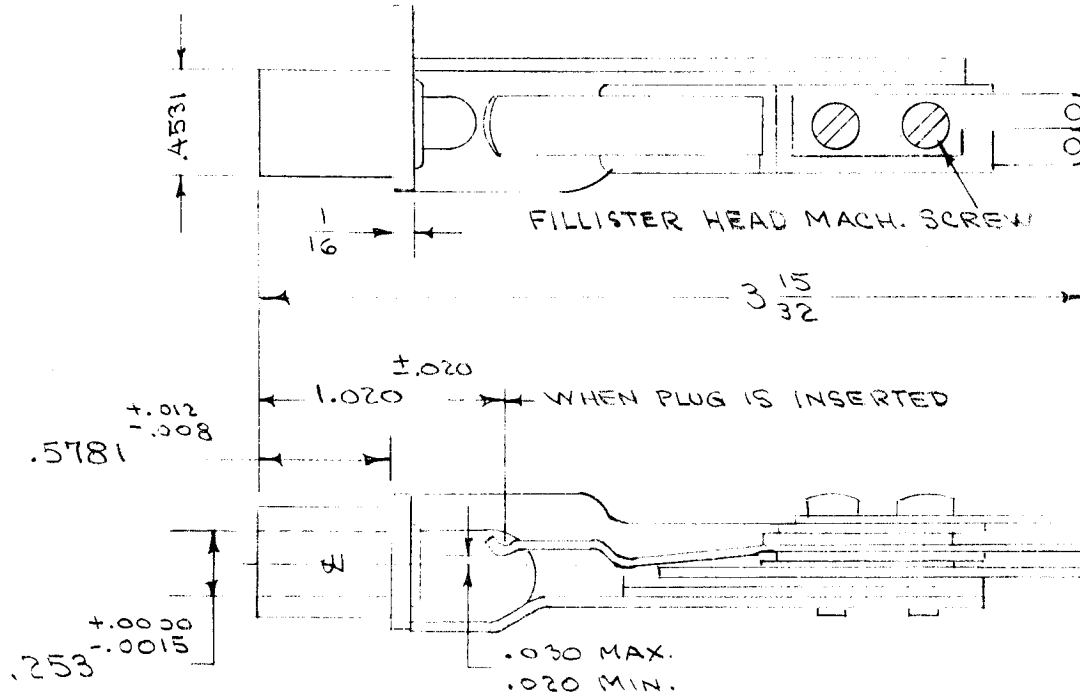

DIAGRAM OF JACK



DIMENSIONS FOR REF. ONLY
JACKS IN ACC. WITH SPEC. JAN-J-641 & AMEND.

REQ.	ITEM	PART NO.	DESCRIPTION	SYMBOL
		#	THE TECHNICAL MATERIEL CORP. MAMARONECK, NEW YORK	
		STOCK SIZE		
		#	JACK, TELEPHONE TYPE	
		MATERIAL	WEIGHT PER PC.	
		TYPE & TEMPER	LG 11/13/52	P.B
			DRAWN	ELEC. DES. APP.
			MECH. DES. APP.	
		HEAT TREAT. SPEC.	CHECKED	FINAL APPROVAL
		FINISH & SPEC. NO.		JJ-024

ISSUE	ITEM	CHANGED FROM	DATE	CN. NO.	DRAFTS	CHECKER	ENG. APP.

TOLERANCES	SCALE
ALL OTHERS DEC. DIM. ± .005 FRAC. DIM. ± 1/64 ANGULAR DIM. ±	DRILL, PUNCH, COMMERCIAL STOCK SIZES AND MANUFACTURERS TOLERANCES ARE NOT INCLUDED.

IF IT IS FOUND DESIRABLE TO CHANGE ANY TOLERANCE OR OTHER DETAIL SPECIFIED ON THIS DRAWING NOTIFY THE PURCHASER PROMPTLY.

STANDARD DRAWING

JJ-026

MAXIMUM ALLOWABLE TOLERANCES HAVE BEEN DETERMINED AND DEVIATIONS WILL BE CAUSE FOR REJECTION. REMOVE ALL BURRS AND SHARP EDGES

USED ON

MODEL	PROJECT NO.	ASS'Y. NO.	DATE
-------	-------------	------------	------

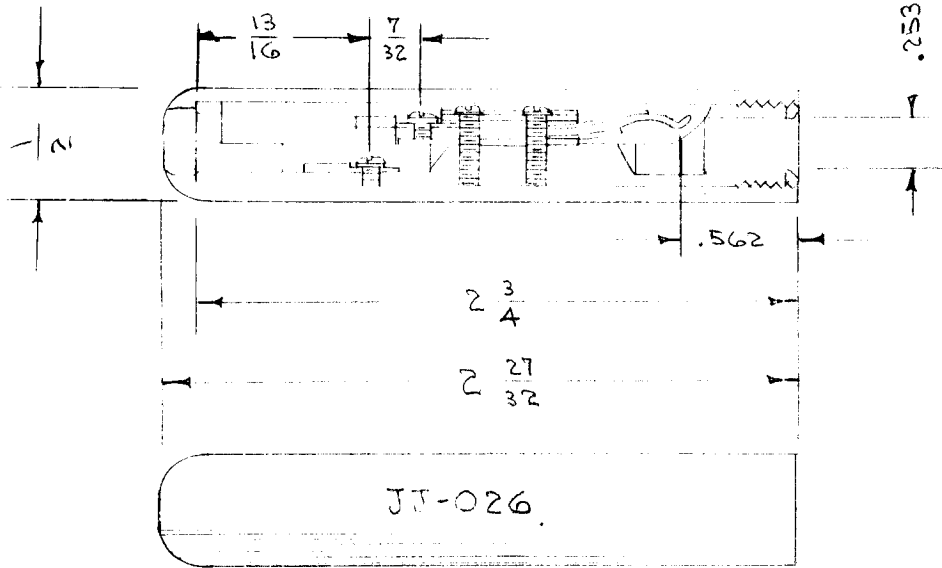

NOTE
PLASTIC (BLACK MOLDED) SHELL

LETTERS TO BE 1/8 HIGH GOTHIC - WHITE FILLED

DIM. FOR REF. ONLY

JACK TO BE IN ACC. WITH JAN. J-641 & AMEND.

REQ.	ITEM	PART NO.	DESCRIPTION	SYMBOL
	#		THE TECHNICAL MATERIEL CORP. MAMARONECK, NEW YORK	
		STOCK SIZE		
	#	#	JACK, TELEPHONE	
		MATERIAL		
		WEIGHT PER PC.		
			CDD 1-13-53	
		TYPE & TEMPER	DRAWN	ELEC. DES. APP.
				MECH. DES. APP.
		HEAT TREAT. SPEC.	<i>JAD</i> CHECKED SUPERVISOR JK-26 (JAN-J-641)	
		FINISH & SPEC. NO.	FINAL APPROVAL JJ-026	

ISSUE	ITEM	CHANGED FROM	DATE	CN. NO.	DRAFTS	CHECKER	ENG. APP.
-------	------	--------------	------	---------	--------	---------	-----------

TOLERANCES

SCALE #

ALL OTHERS

DEC. DIM. ±
FRAC. DIM. ±
ANGULAR DIM. ±

DRILL, PUNCH, COMMERCIAL STOCK SIZES AND MANUFACTURERS TOLERANCES ARE NOT INCLUDED.

THE CONTENTS OF THIS DRAWING ARE THE EXCLUSIVE PROPERTY OF THIS TECHNICAL MATERIEL CORP. ITS UNAUTHORIZED USE OR REPRODUCTION IN WHOLE OR IN PART IS STRICTLY FORBIDDEN.

REQ. PER UNIT

1

MODEL

SPU-2

USED ON

ASS'Y. NO.

DATE

8-24-62

JJ-083

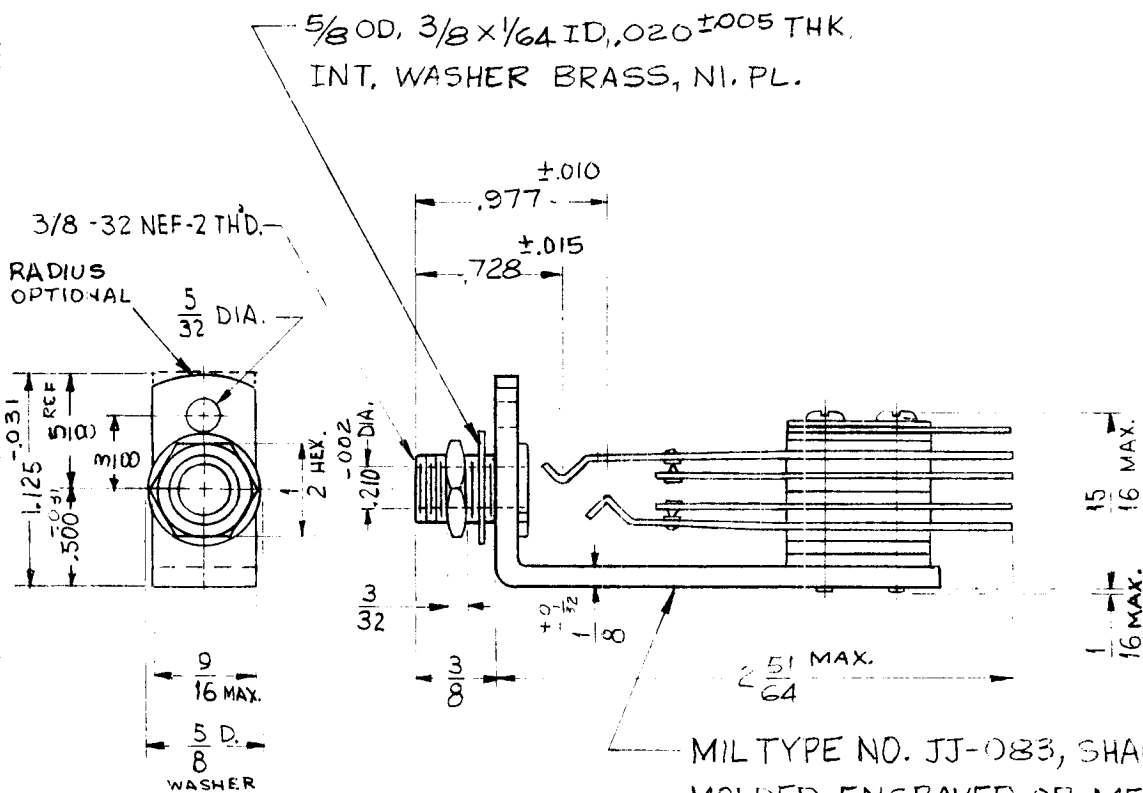

SPECIFICATIONS

MECHANICAL -

FRAME - BRASS, NICKEL PLATED
 SPRINGS - SPECIAL ALLOY, SPRING TEMPERED,
 NICKEL SILVER WITH SOLDER LUGS
 HOT TINNED
 BUSHING - H.H. BRASS, BRIGHT NICKEL PLATED

ELECTRICAL -

INSULATION - TYPE XXYP PAPER BASE.
 PHONELIC SPACERS (TYPE PBE-P
 PER MIL-P-3115A). BAKELITE
 TUBING THROUGH STACK

MIL TYPE NO. JJ-083, SHALL BE
 MOLDED, ENGRAVED OR METAL STAMPED
 ON BOTTOM OF PLATE

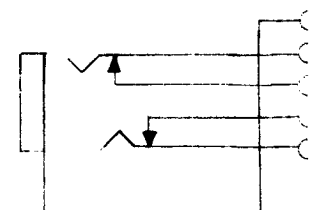

SCHEMATIC
 DIAGRAM

MATING PLUGS: MIL TYPES
 PJ-068, PJ-309.

REF. MIL TYPE JJ-083 PER MIL-J-641B & MIL-J-641/10A

REQ.	ITEM	PART NO.	STRUMMER	DESCRIPTION	SYMBOL							
				THE TECHNICAL MATERIEL CORP. MAMARONECK, NEW YORK JACK, TELEPHONE								
SYM	DESCRIPTION	DATE	CH. NO.	DRAFTS	CHECKER	ENG. APP.	MATERIAL					
UNLESS OTHERWISE SPECIFIED: DIMENSIONS ARE IN INCHES TOLERANCES ON FRAC. ± 1/64 DEC. ± .005 ANGLES ± 1/2°		SCALE: MAXIMUM ALLOWABLE TOLERANCES HAVE BEEN DETERMINED AND ANY DEVIATIONS WILL BE CAUSE FOR REJECTION. REMOVE ALL BURRS AND SHARP EDGES										
							TYPE & TEMPER	HEATTREAT. SPEC.	DRAWN	CHECKED	FINAL APPROVAL	
											JJ-083	
							FINISH & SPEC. NO.		ELEC. DES. APP.	MECH. DES. APP.		

IF IT IS FOUND DESIRABLE TO CHANGE ANY TOLERANCE OR OTHER DETAIL SPECIFIED ON THIS DRAWING NOTIFY THE PURCHASER PROMPTLY.

MAXIMUM ALLOWABLE TOLERANCES HAVE BEEN DETERMINED AND DEVIATIONS WILL BE CAUSE FOR REJECTION. REMOVE ALL BURRS AND SHARP EDGES

STANDARD DRAWING

JJ-089

A

USED ON

MODEL

PROJECT NO.

ASS'Y. NO.

DATE

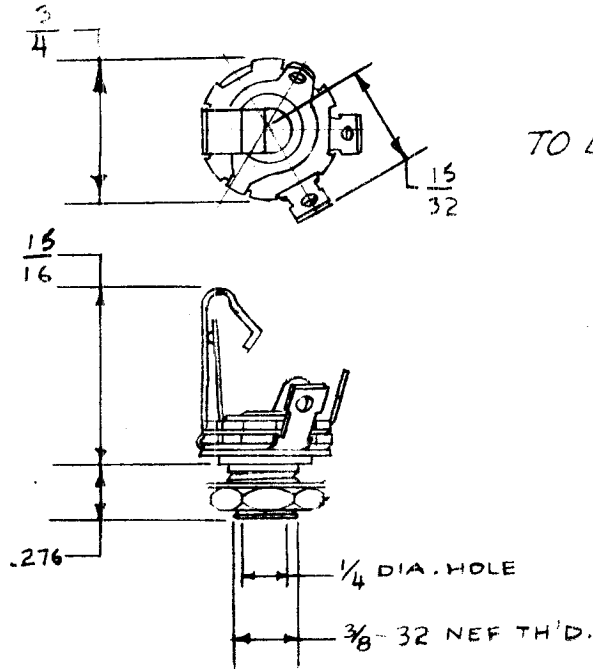

TO BE SUPPLIED BY MFR.

BRASS NICKEL PLATED LOCKNUT 3/8-32 THREAD X 3/32 THICK,
1/2 ACROSS FLATS.
BRASS NICKEL PLATED WASHER 5/8 O.D. X 1/16 THICK.

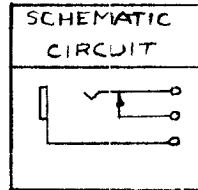

TMC EQUIV.

FW 37MSN - FLAT WASHER.
NTH 3732 BN16 - NUT HEXAGON.

DIMENSIONS FOR REF. ONLY

REF: SWITCHCRAFT INC. C-12 A

REQ.	ITEM	PART NO.	DESCRIPTION	SYMBOL
		—//—	THE TECHNICAL MATERIEL CORP. MAMARONECK. NEW YORK	
		STOCK SIZE		
		—//—	JACK	
		MATERIAL WEIGHT PER PC.		
		—//—	15 12 5-52	
		TYPE & TEMPER		
		—//—	DRAWN	
		HEAT TREAT. SPEC.		
		—//—	CHECKED	
		FINISH & SPEC. NO.		
			FINAL APPROVAL	
			JJ-089	A

A	1	Hdware info. added	1/23/57	1	SC	16	
ISSUE	ITEM	CHANGED FROM	DATE	CN. NO.	DRAFTS	CHECKER	ENG. APP.

TOLERANCES

SCALE FULL SIZE

ALL OTHERS

DEC. DIM. ±.005
FRAC. DIM. ±1/64
ANGULAR DIM. ±

DRILL, PUNCH, COMMERCIAL STOCK
SIZES AND MANUFACTURERS
TOLERANCES ARE NOT INCLUDED.

IF IT IS FOUND DESIRABLE TO CHANGE ANY TOLERANCE OR OTHER DETAIL SPECIFIED ON THIS DRAWING NOTIFY THE PURCHASER PROMPTLY.

STANDARD DRAWING

JJ-100 C

MAXIMUM ALLOWABLE TOLERANCES HAVE BEEN DETERMINED AND DEVIATIONS WILL BE CAUSE FOR REJECTION.
REMOVE ALL BURRS AND SHARP EDGES

USED ON

MODEL	PROJECT NO.	ASS'Y. NO.	DATE
-------	-------------	------------	------

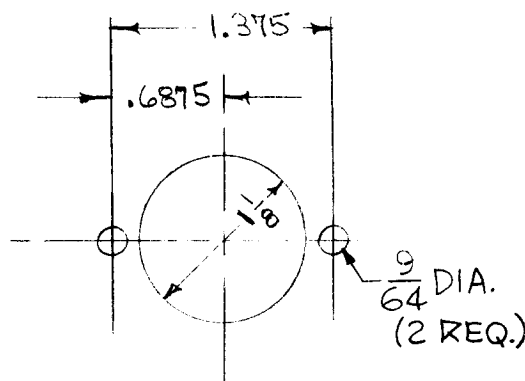
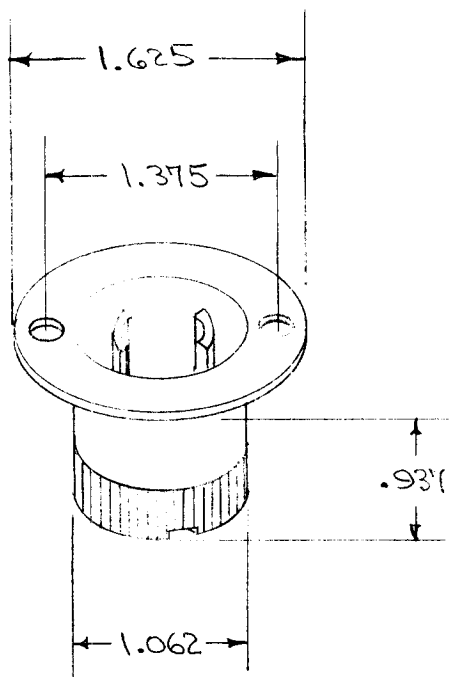

DRILLING PLAN

SPECIFICATIONS

NUMBER OF CONTACTS — 2
SHIELDING — NONE
BODY MATERIAL — BAKELITE
 TYPE CFG. PER MIL-M-14F
CONTACTS — BRASS
SHELL — NICKEL PLATED BRASS
 0.025 THICK
CURRENT RATING: —
 — 10AMPS AT 250VAC
 — 15AMPS AT 125VAC
POLARIZATION — NONE
LOCKING — BY ROTATING MATE
WIRE SIZE — 12 AWG MAX
MATING CONNECTOR — TMC-PL-100

REQ.	ITEM	PART NO.		DESCRIPTION			SYMBOL
				THE TECHNICAL MATERIEL CORP.			
				MAMARONECK. NEW YORK			
				RECEPTACLE, MALE, TWIST			
				LOCK			
				C.D.D. 8/28/54			
				G.T.O.			
				DRAWN			
				ELEC. DES. APP.			
				MECH. DES. APP.			
				CHECKED			
				FINAL APPROVAL			
				JJ-100			C
				FINISH & SPEC. NO.			

ISSUE	ITEM	CHANGED FROM	DATE	CN. NO.	DRAFTS	CHECKER	ENG. APP.
C		SPECS. REWRITTEN	3.12.64	11030	WB		
B	1	9/64 Dia. Holes Clarified	4-2-62	6569	EG		
#	#	REDRAWN - NO CHANGE	9/28/54	#	C.D.D.		

TOLERANCES		SCALE	5401-43 (7466)
ALL OTHERS:		DRILL, PUNCH, COMMERCIAL STOCK SIZES AND MANUFACTURERS TOLERANCES ARE NOT INCLUDED.	
DEC. DIM. ±	FRAC. DIM. ±		
ANGULAR DIM. ±			