

ID-214

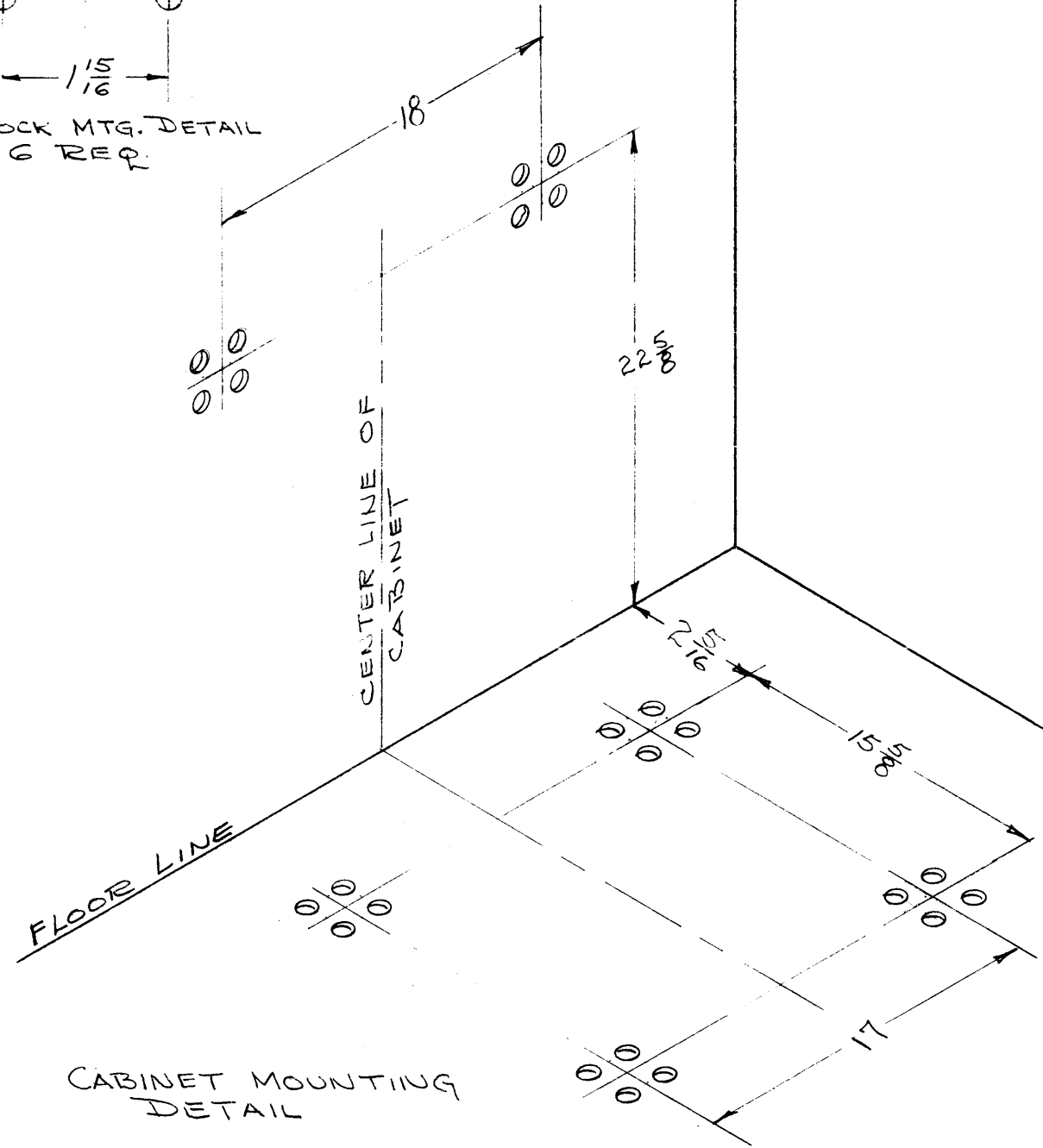
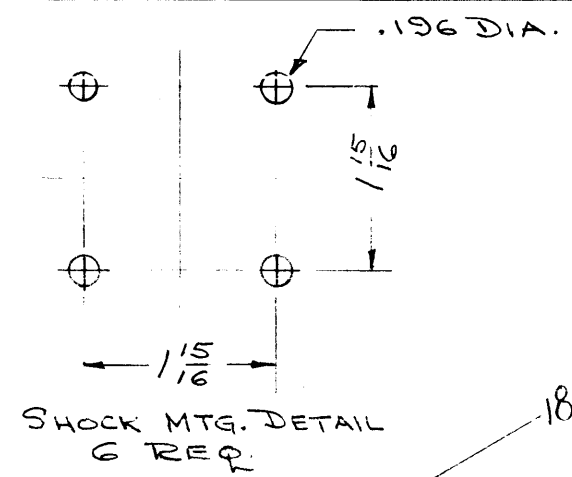
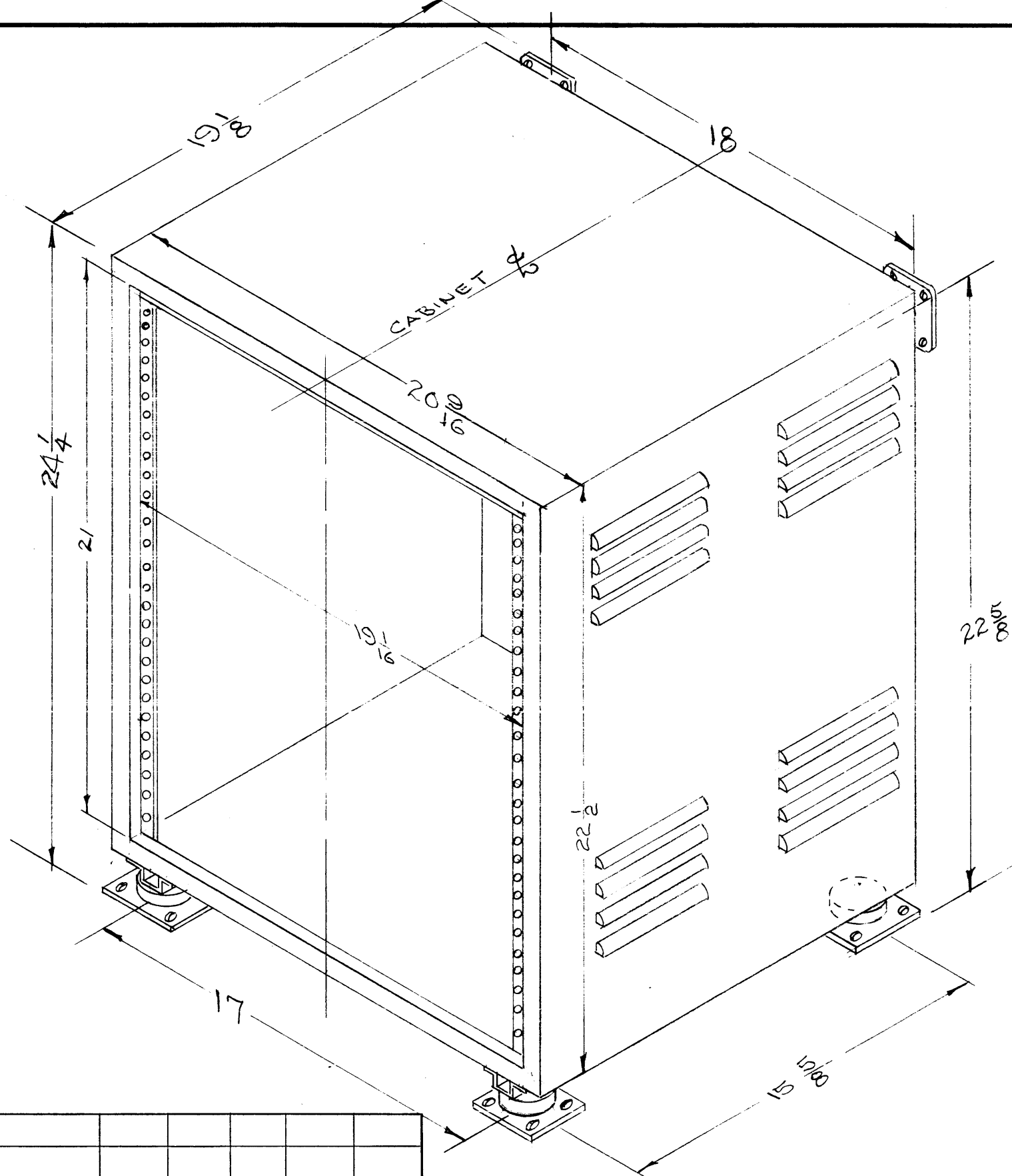

CABINET MOUNTING DETAIL

ISSUE ITEM	CHANGED FROM	DATE	CH. NO.	DRAFTS	CHECKER	ENG. APP.
TOLERANCES						
DEC. DIM. ±		SCALE: NONE				
FRAC. DIM. ± 1/64		MAXIMUM ALLOWABLE TOLERANCES HAVE BEEN DETERMINED AND ANY DEVIATIONS WILL BE CAUSE FOR REJECTION.				
ANGULAR DIM. ±		REMOVE ALL BURRS AND SHARP EDGES				

1	CY-2416/U	A-1524	9-3-58
1	RAK-4	A-1524	4-7-58
REQ. PER UNIT	MODEL	PROJECT NO.	ASS'Y. NO.
			DATE
USED ON			

REQ. ITEM	PART NO.	DESCRIPTION	SYMBOL
THE TECHNICAL MATERIEL CORP. MAMARONECK, NEW YORK			
CABINET INSTALLATION			
RAK-4, (CY-2416/U)			
TYPE & TEMPER		HEAT TREAT. SPEC.	FINISH & SPEC. NO.
DRAWN		CHECKED	FINAL APPROVAL
ELEC. DES. APP.		MECH. DES. APP.	ID-214