

ID-196

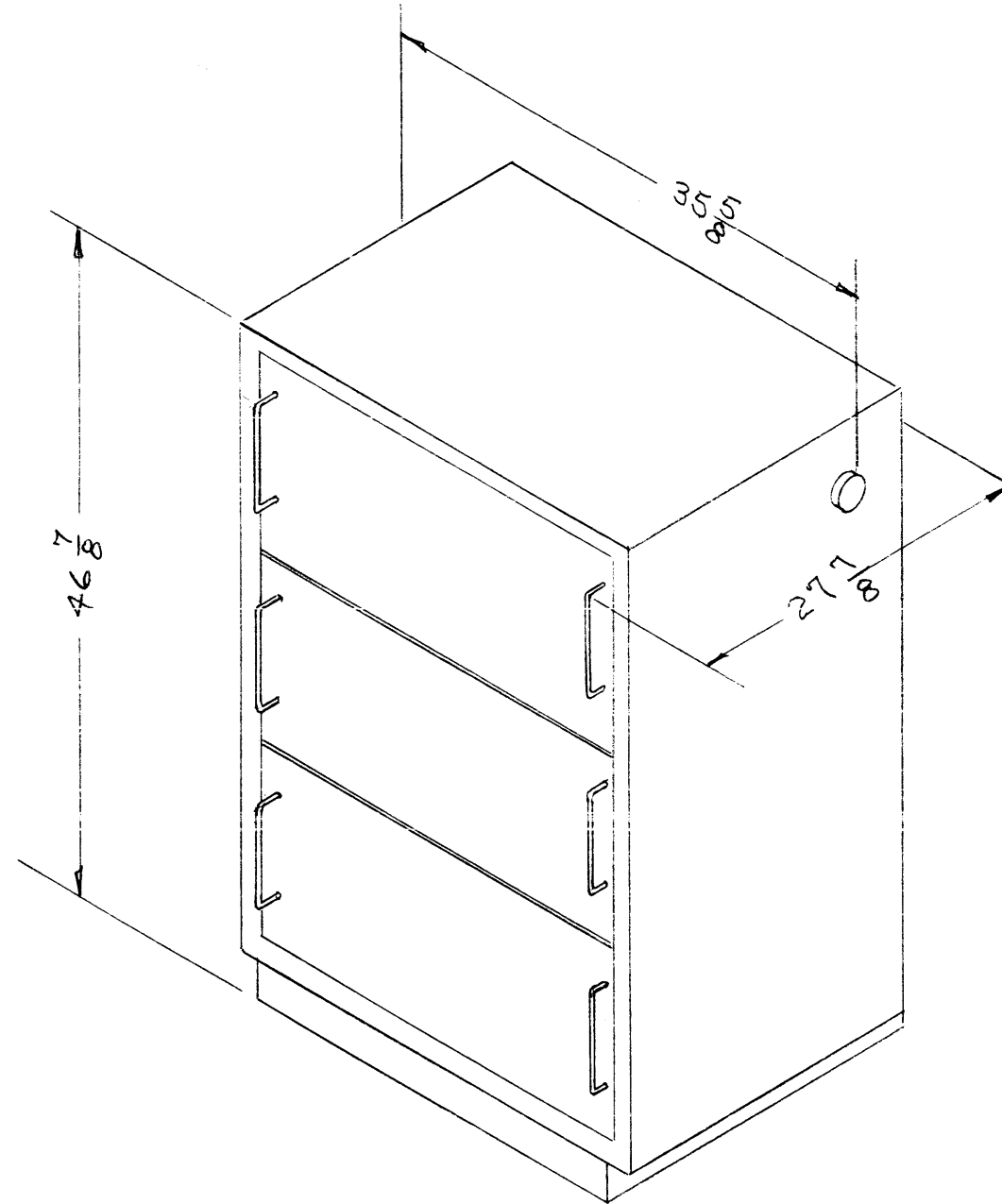

NO UNAUTHORIZED PERSONS REPRODUCE THIS DRAWING  
 THE TECHNICAL MATERIEL CORPORATION claims  
 proprietary right in the material disclosed hereon.  
 This drawing is issued in confidence for engineering  
 information only and may not be reproduced or used  
 to manufacture any thing shown hereon without per-  
 mission from THE TECHNICAL MATERIEL CORPORA-  
 TION to the user. This drawing is loaned for mutual  
 assistance and is subject to recall at any time.

Property of:  
 THE TECHNICAL MATERIEL CORPORATION  
 MAMARONECK, NEW YORK

65-196

ISSUE	ITEM	CHANGED FROM	DATE	CH. NO.	DRAFTS	CHECKER	ENG. APP.
TOLERANCES			SCALE:				
DEC. DIM. ±			MAXIMUM ALLOWABLE TOLERANCES HAVE				
FRAC. DIM. ±			BEEN DETERMINED AND ANY DEVIATIONS				
ANGULAR DIM. ±			WILL BE CAUSE FOR REJECTION.				
			REMOVE ALL BURRS AND SHARP EDGES				

REQ. PER UNIT	MODEL	PROJECT NO.	ASS'Y. NO.	DATE

REQ.	ITEM	PART NO.	DESCRIPTION	SYMBOL
			THE TECHNICAL MATERIEL CORP. MAMARONECK, NEW YORK	
STOCK SIZE			DIMENSIONAL OUTLINE DRAWING	
MATERIAL			MODEL GPT-750	
TYPE & TEMPER		HEAT TREAT. SPEC.	DRAWN	CHECKED
			3/11/57	H. J. J.
FINISH & SPEC. NO.			ELEC. DES. APP.	MECH. DES. APP.
				ID-196