

H1116

REVISIONS						
SYM	DESCRIPTION	DATE	E.M.N. NO.	DRAFT	CHKD	APPD
X	EXPERIMENTAL RELEASE	6/4/64	X	JL		
Q	ORIGINAL RELEASE FOR PRODUCTION	1-18-65	Q	JM	J.M	

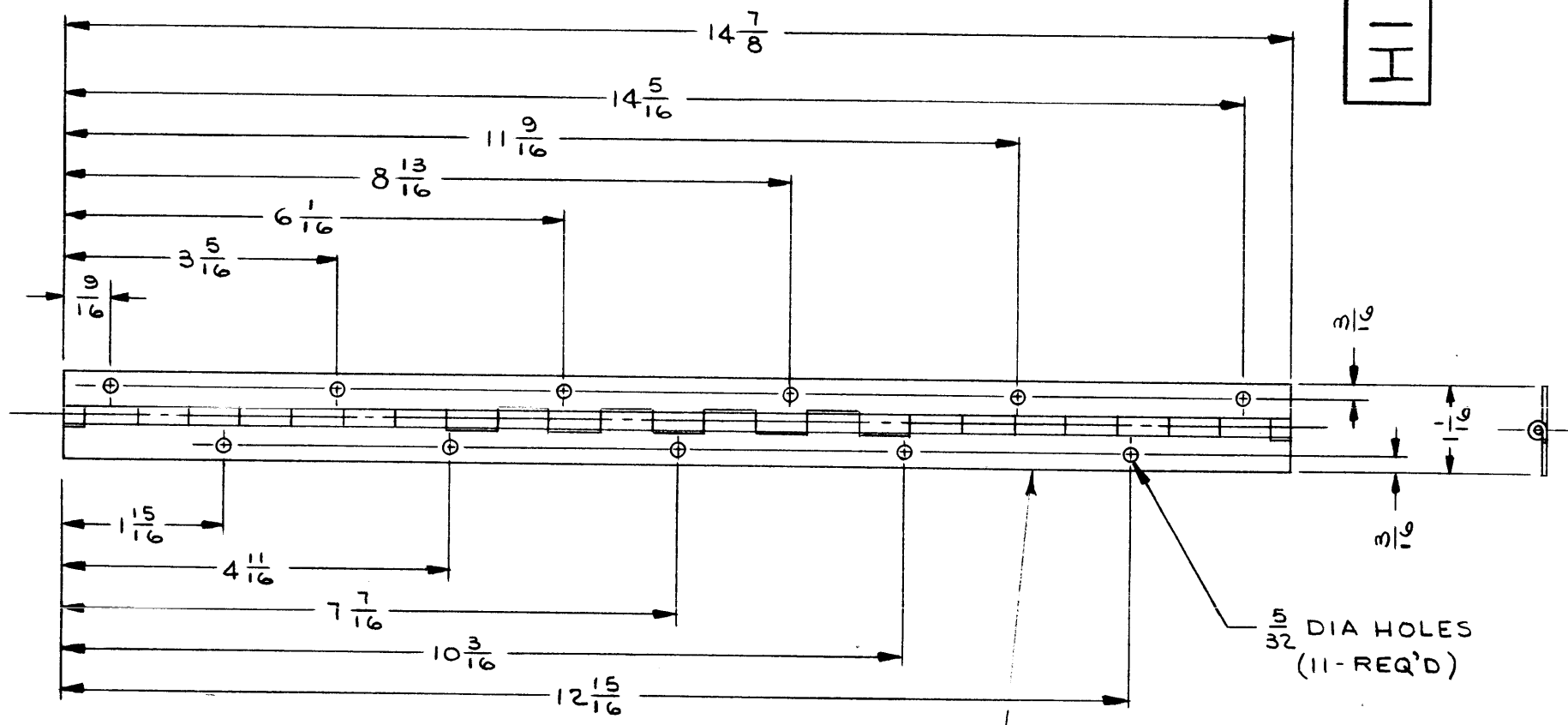

METAL STAMP TMC PART NO. 1/8 HIGH GOTHIC.
WITH LATEST REV. LETTER

SPECIFICATIONS

MATERIAL - ALUMINUM 5052-H32
GAUGE - .040 THK
PIN MATERIAL - DURALUMINUM
PIN DIAMETER - .095 DIA
FINISH - YELLOW IRIDITE PER S404

QTY./UNIT	MODEL USED ON	ASS'Y. NO.
2	RTIA-1	A-4001, A4002
1	RTMU-1	A3907
SCALE	CODE	
1:2	C	S401-264

REQ'D.	ITEM	PART NUMBER	DESCRIPTION	SYMBOL
F. E. EATON LIST OF MATERIAL				
MATERIAL		SEE NOTES		
FINISH		SEE NOTES		
		THE TECHNICAL MATERIEL CORP. MAMARONECK, NEW YORK		
		HINGE - P.C. CARD BIN		
UNLESS OTHERWISE SPECIFIED DIMENSIONS ARE IN INCHES AND INCLUDE CHEMICALLY APPLIED OR PLATED FINISHES		DRAWN J. LESHINSKI DATE 6/3/64	FINAL APPROVAL 	DATE
		CHECKED J. MUNFORD @ DATE 1-18-65		
		ELECT. DES. 	DATE 1/18/65	H1116
		MECH. DES. W. JORDAN	DATE 1/18/65	SHEET
		DECIMALS .X ± .05 .XX ± .01 .XXX ± .05	FRACTIONS ± 1/64 ANGLES ± 0° 30'	TOLERANCES
NOTES				
THE CONTENTS OF THIS DRAWING ARE THE EXCLUSIVE PROPERTY OF THE TECHNICAL MATERIEL CORP. ITS UNAUTHORIZED USE OR REPRODUCTION IN WHOLE OR IN PART IS STRICTLY FORBIDDEN.				