

TMC P/N	MFG P/N	GEAR INFORMATION							REMARKS
		PITCH	NO. OF TEETH	A (PD)	B (OD)	C	D	PRESSURE ANGLE	
GR217-1	G7-80 OR EQUIV.	48	80	1.6666	1.7083	+.0003 -.0000 .250 BORE	.187	20	HUB TO BE MACH OFF FLUSH WITH GEAR WALL

GR217

REVISIONS					
SYM	DESCRIPTION	DATE	E.M.N. NO.	DRAFT	CHKD
Ø	ORIGINAL RELEASE	4-2-65		G.D.L	<i>[Signature]</i>

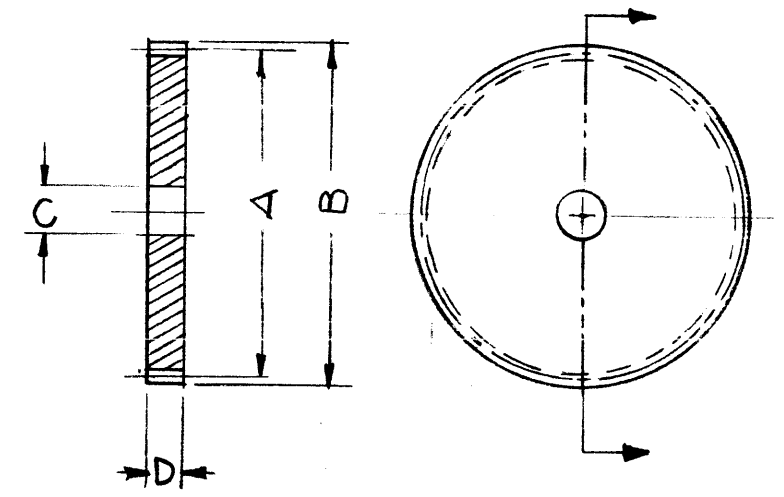

STANDARD DRAWING

1	CHGR-3	A 4175
Q'TY./UNIT	MODEL USED ON	ASS'Y. NO.
SCALE 1:1	CODE C	S401-350

NOTES

THE CONTENTS OF THIS DRAWING ARE THE EXCLUSIVE PROPERTY OF THE TECHNICAL MATERIEL CORP. ITS UNAUTHORIZED USE OR REPRODUCTION IN WHOLE OR IN PART IS STRICTLY FORBIDDEN.

REQ'D.	ITEM	PART NUMBER	DESCRIPTION	SYMBOL
J. ANGER LIST OF MATERIAL				
MATERIAL		THE TECHNICAL MATERIEL CORP. MAMARONECK, NEW YORK		
FINISH		TITLE		
S104 CLEAR PASSIVATED (AFTER CUTTING)		GEAR SPUR		
UNLESS OTHERWISE SPECIFIED DIMENSIONS ARE IN INCHES AND INCLUDE CHEMICALLY APPLIED OR PLATED FINISHES		DRAWN G.D.L	DATE 1-25-65	FINAL APPROVAL <i>[Signature]</i>
		CHECKED <i>[Signature]</i>	DATE 4/2/65	DATE 4/2/65
		ELECT. DES. <i>[Signature]</i>	DATE 4/2/65	DATE 4/2/65
		MECH. DES.	DATE	DATE
		SHEET		REV. LTR.