

THE CONTENTS OF THIS DRAWING ARE THE EXCLUSIVE PROPERTY OF THE TECHNICAL MATERIEL CORP. ITS UNAUTHORIZED USE FOR REPRODUCTION IN WHOLE OR IN PART IS STRICTLY FORBIDDEN.

REQ. PER UNIT
2

MODEL
GPT-200K (AK 395)

USED ON
ASSY. NO. A-3242

DATE
8-6-63

GR-195 0

(2) 8-32 TAP
90° APART.

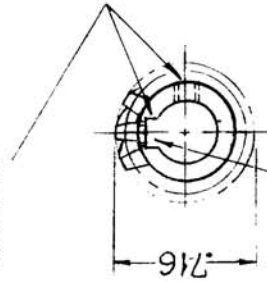

1/8 WIDE X .070 DEEP
KEYWAY THRU.

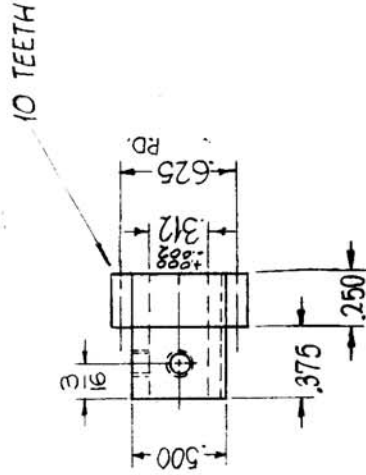

SYMBOL
O

DESCRIPTION
ORIGINAL RELEASE FOR PRODUCTION

DATE
3-3-64

SCALE
1" = 1"

CHECKER
ENG. APP.

DRAFTS
CH. NO.

STAINLESS STEEL

303

MATERIAL

TYPE & TEMPER

HEAT TREAT. SPEC.

SRS

DRAWN
SRG

CHECKED
SRG

FINAL APPROVAL
RAC 3-30-64

DECIMALS
.X ± .05
.XX ± .01
.XXX ± .005

TOLERANCES
FRACTIONS
± 1/64
ANGLES
± 0° 30'

CODE
C

S 401-15 (H1610R MOD.)

FINISH & SPEC. NO.
S-104-PASSIVATE

STAINLESS STEEL

303

MATERIAL

TYPE & TEMPER

HEAT TREAT. SPEC.

SRS

DRAWN
SRG

CHECKED
SRG

FINAL APPROVAL
RAC 3-30-64

REQ. ITEM

PART NO.

F. BUDETTI

SYMBOL

STOCK SIZE

THE TECHNICAL MATERIEL CORP.
MAMARONECK.
NEW YORK

DESCRIPTION

STAINLESS STEEL

GEAR, HELICAL

DESCRIPTION