

GR-174

REVISIONS

SYM	DESCRIPTION	DATE	E.M.N. NO.	DRAFT	CHKD	APPD
-----	-------------	------	------------	-------	------	------

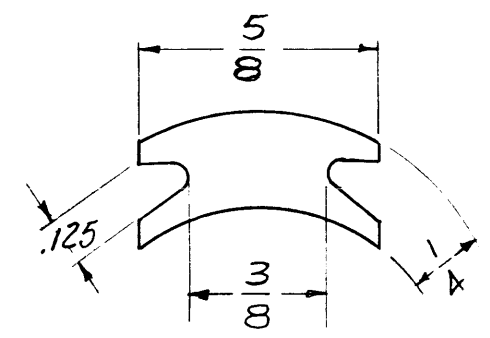

CUTOUT DETAIL
DIMENSION FOR REF. ONLY

~ SPECIFICATIONS ~

- NO. OF TEETH = 84
- DIAMETRAL PITCH = 48
- PITCH DIA. = 1.750
- PRESSURE ANGLE = 20°
- COMM. CLASS 3 TOL.
- TYPE - ANTI-BACKLASH

CRIMP (4 CUTOUTS ON FIXED GEAR ONLY)

SPRING SUITABLE TO PREVENT BACK-LASH 2 REQ'D SP-122

APPROX. .003 SPACING BETWEEN GEARS WITH LIGHT LUBRICATION.

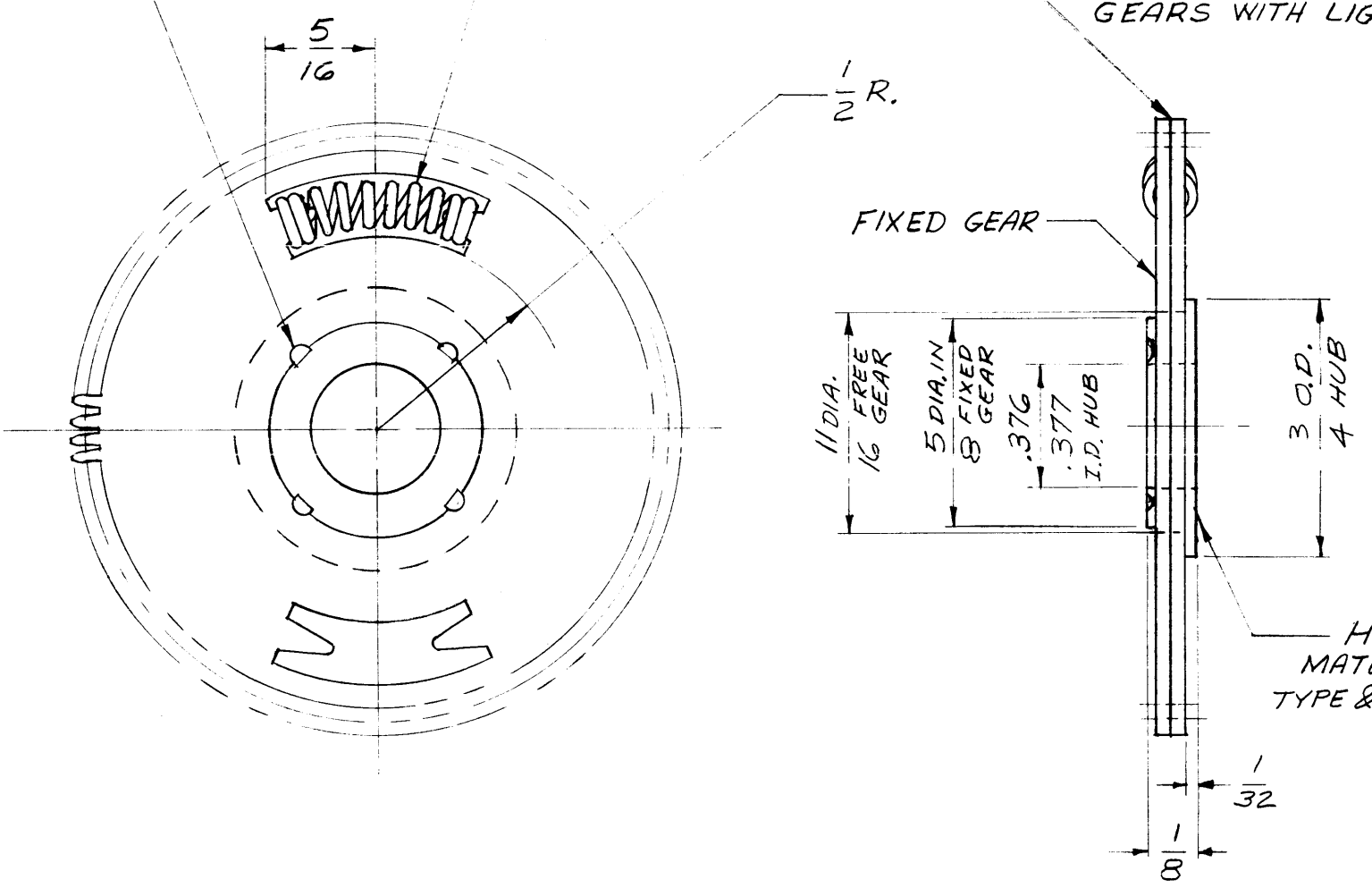

HUB
MATERIAL - ALUMINUM
TYPE & TEMPER - 115-T3

REF. N. J. GEAR WORKS

REQ'D.	ITEM	PART NUMBER	DESCRIPTION	SYMBOL
LIST OF MATERIAL				
MATERIAL .032 THK EACH GEAR ALUMINUM 245-T3			THE TECHNICAL MATERIEL CORP. MAMARONECK, NEW YORK	
FINISH ANODIZE			TITLE SPLIT GEAR ASSY.	
UNLESS OTHERWISE SPECIFIED DIMENSIONS ARE IN INCHES AND INCLUDE CHEMICALLY APPLIED OR PLATED FINISHES			DRAWN W.S.	DATE 5/21/02
			CHECKED JST	DATE 10/29/02
			ELECT. DES.	DATE
			MECH. DES. M6	DATE 10/29/02
			GR-174	
			SHEET	
			REV. LTR.	

2	GPR-92	
Q'TY./UNIT	MODEL USED ON	ASS'Y. NO.
SCALE	CODE	

THE CONTENTS OF THIS DRAWING ARE THE EXCLUSIVE PROPERTY OF THE TECHNICAL MATERIEL CORP. ITS UNAUTHORIZED USE OR REPRODUCTION IN WHOLE OR IN PART IS STRICTLY FORBIDDEN.

NOTES