

REQ. PER UNIT	MODEL	USED ON	DATE
2	CHG	GEAR ASS'Y	11-4-60
			GR-162 A

R.D. = 2.000
 PITCH = 48
 NO. OF TEETH = 96
 HUB { DIA = .500
 PROJ = .250
 BORE = .252 DIA.
 STYLE = PLAIN
 PRESSURE ANGLE = 14 1/2°
 FACE = .125
 A DRILL & TAP 6-32 - 3 REG

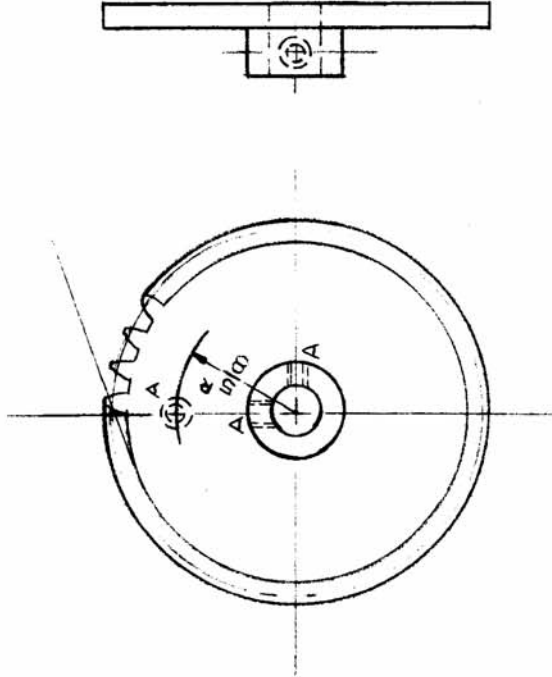

REQ. ITEM	PART NO.	DESCRIPTION	SYMBOL
		THE TECHNICAL MATERIEL CORP.	
		MAMARONECK, NEW YORK	
		GEAR, POT. MTG.	
		MF TUNING	
		ALUMINUM	
		MATERIAL	
		YELLOW IRIDITE	
		FINISH & SPEC. NO.	
		TYPE & TEMPER	
		HEAT TREAT. SPEC.	
		DRAWN	
		CHECKED	
		FINAL APPROVAL	
		MECH. DES. APP	
		ELEC. DES. APP	
		GR-162 A	

A 1 Bore Dim. was .250 Dia
 DATE 2-28-61 CH. NO. 4285 RU
 CHECKER JBS
 ENG. APP.
 SCALE: DO NOT SCALE
 MAXIMUM ALLOWABLE TOLERANCES HAVE BEEN DETERMINED AND ANY DEVIATIONS WILL BE CAUSE FOR REJECTION.
 REMOVE ALL BURRS AND SHARP EDGES

DEC. DIM. ± .0015
 FRAC. DIM. ± 1/64
 ANGULAR DIM. ±