

GR-137 C

USED ON	
REQ. PER UNIT	ASSY. NO.
1	ATS-50TU
1	ATS-70TU
1	ATS-50(70)TU-2
	DATE
	12-18-57
	12-18-57
	6-8-59

O/A OUTSIDE DIA. — .374  
 Pitch Diam. (P.D) — .333"  
 Pitch — 48  
 No. of Teeth — 8  
 Pressure Angle — 14 1/2°  
 Threads — Right Hand  
 Single Type  
 Lead Angle — 3° 35'  
 Lead — .0654

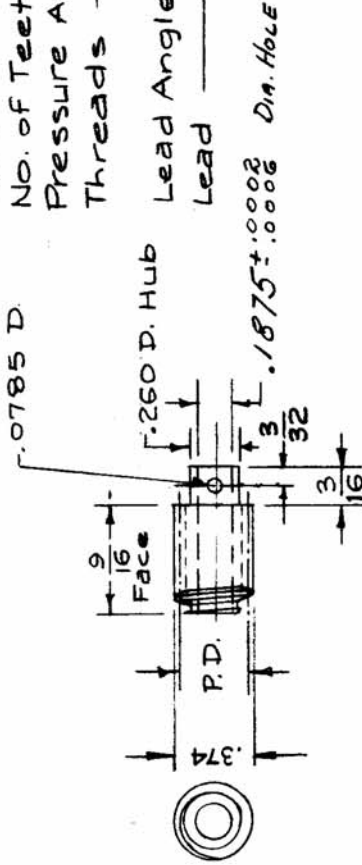

MATES WITH WORM GEAR - GR-136 & GR-146

REQ. ITEM	PART NO.	DESCRIPTION	SYMBOL
C 1	W	THE TECHNICAL MATERIEL CORP. MAMARONECK, NEW YORK	
B 1	W	STEEL	
A 1	W	MATERIAL	
ISSUE ITEM	CHANGED FROM	DATE	CH. NO.
		10-25-61	5757
		9/1/59	1307
		5/26/58	1
		SCALE: S-401-15 (LSH)	
		MAXIMUM ALLOWABLE TOLERANCES HAVE BEEN DETERMINED AND ANY DEVIATIONS WILL BE CAUSE FOR REJECTION. REMOVE ALL BURRS AND SHARP EDGES	
DEC. DIM. ±			
FRAC. DIM. ± 1/64			
ANGULAR DIM. ±			
	TYPE & TEMPER	HEAT TREAT. SPEC.	
	NICKEL PLATE S-135		
	FINISH & SPEC. NO.		
	16/23/58	DRAWN	
	16/23/58	CHECKED	
		FINAL APPROVAL	
		GR-137 C	