

REQ. PER UNIT	MODEL	USED ON	DATE
1	SBE-1	ABSY. NO.	7-22-57
1	SBE-2		5-5-58
1	SBE-3	AP-100	11-30-59

GR-129 A

Pitch Diameter - .750"
 Diametral Pitch - 48
 Number of teeth - 36
 Pressure Angle - 14 1/2°

Dr. & tap 6-32 - 2 Req.
 Class 2

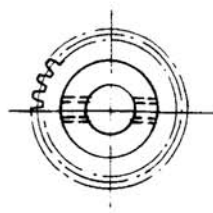
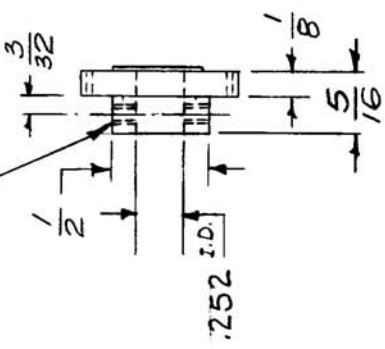

REF: NEW JERSEY GEAR WORKS

REQ. ITEM	PART NO.	DESCRIPTION	SYMBOL
		THE TECHNICAL MATERIEL CORP. MAMARONECK. NEW YORK	
		GEAR, SPUR, .750" P.D.	
		SBE-1	
	672267	RWP	
		CHECKED	
		FINAL APPROVAL	
		GR-129	A
ISSUE ITEM	CHANGED FROM	TOLERANCES	
A 1	Dim. .252 was .250 .251	DEC. DIM. ± .0015 FRAC. DIM. ± 1/16 ANGULAR DIM. ±	
	DATE	CH. NO.	DRAFTS
	2-28-64	4285	RU
	CHECKER	ENG. APP.	
	JOB	JOB	
	SCALE: FULL	1-1003	
MAXIMUM ALLOWABLE TOLERANCES HAVE BEEN DETERMINED AND ANY DEVIATIONS WILL BE CAUSE FOR REJECTION. REMOVE ALL BURRS AND SHARP EDGES			
	TYPE & TEMPER	HEAT TREAT. SPEC.	
	92B		
	FINISH & SPEC. NO.		