

REVISIONS							
E.M.N. NO.	DRAFT	CHKD	ZONE	LTR	DESCRIPTION	DATE	APPROVED
	GDL			Ø	ORIGINAL RELEASE FOR PRODUCTION	3-20-91	

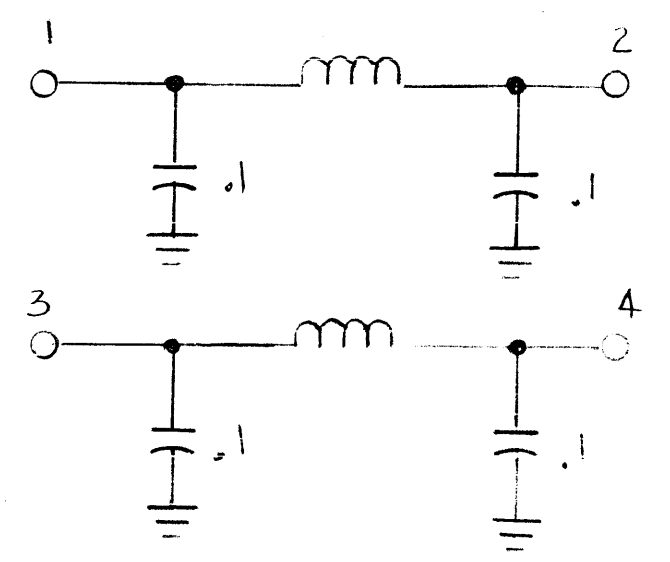

BOTTOM VIEW
MTG. HOLES 2REQ.

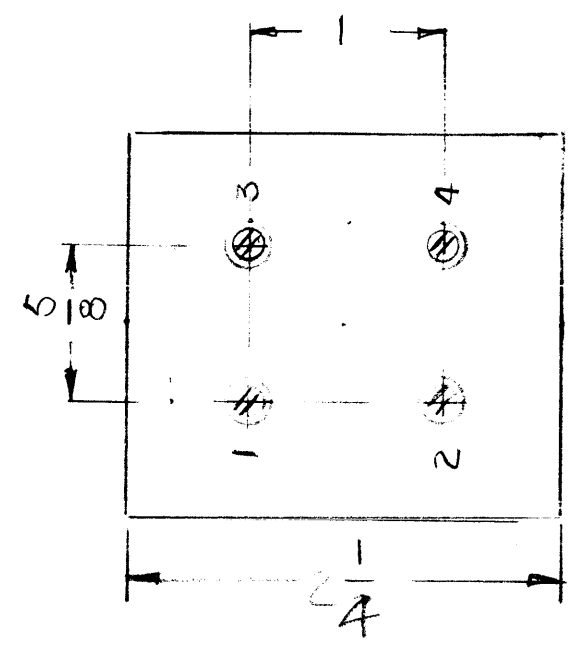
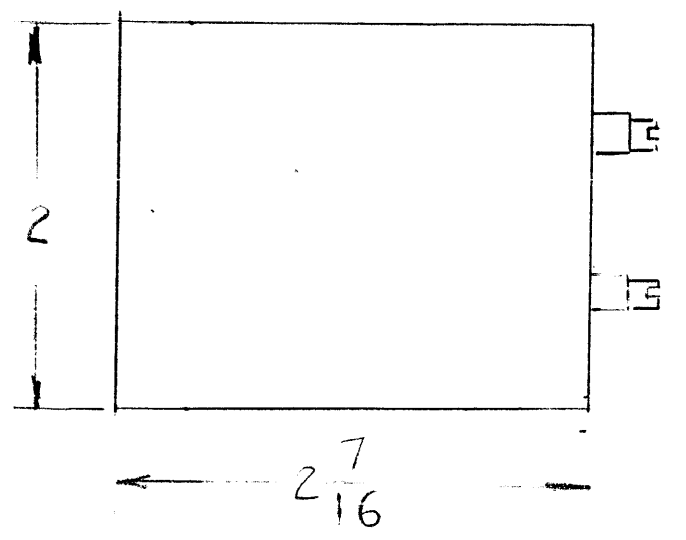
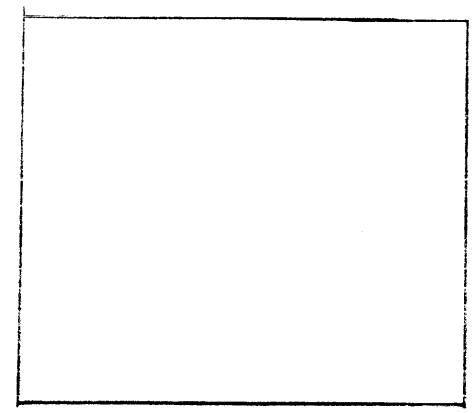
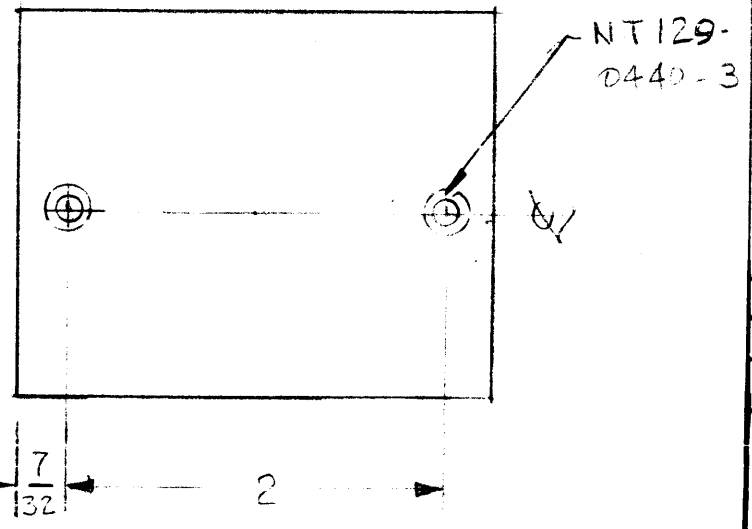

QTY / UNIT	MODEL USED ON	ASS'Y NO.
1	DMC-2XB	

APPLICATION

CODE	
------	--

NOTICE TO PERSONS RECEIVING THIS DRAWING
 THE TECHNICAL MATERIEL CORPORATION claims proprietary right in the material disclosed hereon. This drawing is issued in confidence for engineering information only and may not be reproduced or used to manufacture anything shown hereon without permission from THE TECHNICAL MATERIEL CORPORATION to the user. This drawing is loaned for mutual assistance and is subject to recall at any time.

UNLESS OTHERWISE SPECIFIED DIMENSIONS ARE IN INCHES AND INCLUDE CHEMICALLY APPLIED OR PLATED FINISHES

DECIMALS	FRACTIONS
.X ± .05	1/64
.XX ± .01	TOLS. ANGLES
.XXX ± .005	0° - 30'

MATERIAL

FINISH

REQ'D	ITEM	PART NUMBER	DESCRIPTION	SYM.
LIST OF MATERIAL				
THE TECHNICAL MATERIEL CORP. MAMARONECK, NEW YORK				
LINE, FILTER				
FINAL APPROVAL		DATE		
MECH. DES.		DATE		
ELECT. DES.		DATE		
CHECKED		DATE		
DRAWN	G.D.L.	DATE		
		3-20-91		
SIZE	CODE IDENT. NO.	DWG NO.	ISSUE	
B	82679	FX 311		
SCALE	1%1	SHEET	OF	