

IF IT IS FOUND DESIRABLE TO CHANGE ANY TOLERANCE OR OTHER DETAIL SPECIFIED ON THIS DRAWING NOTIFY THE PURCHASER PROMPTLY.

MAXIMUM ALLOWABLE TOLERANCES HAVE BEEN DETERMINED AND DEVIATIONS WILL BE CAUSE FOR REJECTION. REMOVE ALL BURRS AND SHARP EDGES

STANDARD DRAWING

FS-105

USED ON

| TMC NO. | MFG. NO. | STUD MARKED | RANGE OF TOT. THICKNESS TO BE FASTENED | ASSY. NO. | DATE |
|-----------|------------|-------------|--|-----------|------|
| FS-105-1 | 98-05-2-8 | 08 | .071 - .080 | | .195 |
| FS-105-2 | 98-05-2-9 | 09 | .081 - .090 | | .205 |
| FS-105-3 | 98-05-2-10 | 10 | .091 - .100 | | .215 |
| FS-105-4 | 98-05-2-11 | 11 | .101 - .110 | | .225 |
| FS-105-5 | 98-05-2-12 | 12 | .111 - .120 | | .235 |
| FS-105-6 | 98-05-2-13 | 13 | .121 - .130 | | .245 |
| FS-105-7 | 98-05-2-14 | 14 | .131 - .140 | | .255 |
| FS-105-8 | 98-05-2-15 | 15 | .141 - .150 | | .265 |
| FS-105-9 | 98-05-2-16 | 16 | .151 - .160 | | .275 |
| FS-105-10 | 98-05-2-26 | 26 | .251 - .260 | | .375 |

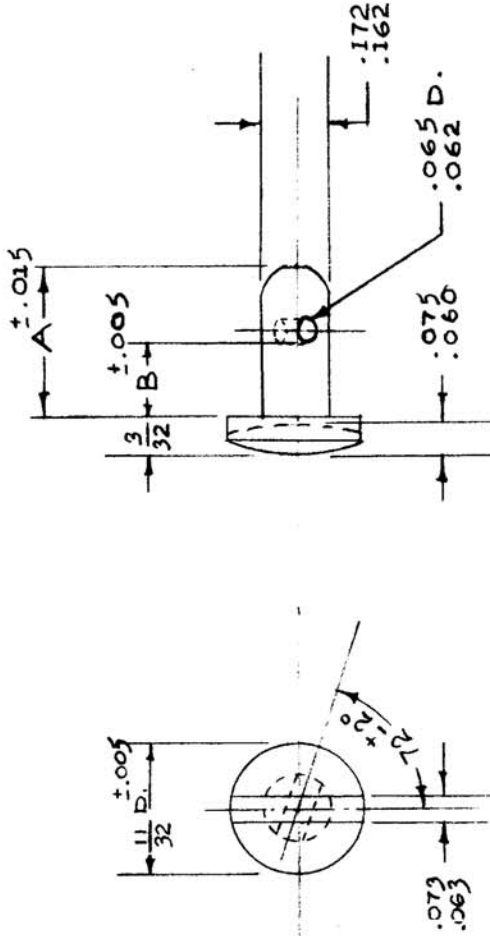

DIMENSIONS FOR REF. ONLY.

REF.: SHAKE PROOF INC.

| REQ. ITEM | PART NO. | DESCRIPTION | SYMBOL |
|-----------|----------|--|--------|
| | ff | THE TECHNICAL MATERIEL CORP. MAMARONECK, NEW YORK | |
| | | STEEL | |
| | | MATERIAL | |
| | | TYPE & TEMPER | |
| | | WEIGHT PER PC. | |
| | | HAARDENED & TEMP. | |
| | | HEAT TREAT. SPEC. | |
| | | CADMIUM PLATE (S-105) FINISH & SPEC. NO. | |
| | | NO. 2 | |
| | | G.T.O | |
| | | ELEC. DES. APP. | |
| | | MECH. DES. APP. | |
| | | FINAL APPROVAL | |
| | | FS-105 | |
| | | A | |

| ISSUE ITEM | CHANGED FROM | DATE | C.N.O. | DRAFTS CHECKER | ENG. APP. |
|---|--------------|--------|--------|--------------------|---------------|
| A 1 | -10 ADDED | 7/2/53 | 1 | C.D.D. <i>W.B.</i> | <i>P.L.B.</i> |
| TOLERANCES | | | | | |
| SCALE 2" TO 1" | | | | | |
| DRILL, PUNCH, COMMERCIAL STOCK SIZES AND MANUFACTURERS TOLERANCES ARE NOT INCLUDED. | | | | | |
| DEC. DIM. ± | | | | | |
| ALL OTHERS ANGULAR DIM. ± | | | | | |