

REQ. PER UNIT	1	USED ON	FP-177	DATE	4-11-60
MODEL	CMO	ASSY. NO.			

A ~ 30 DR. (.128 DIA.) 2 REQ.
 B ~ 17/64 (.265 DIA.) 1 REQ.

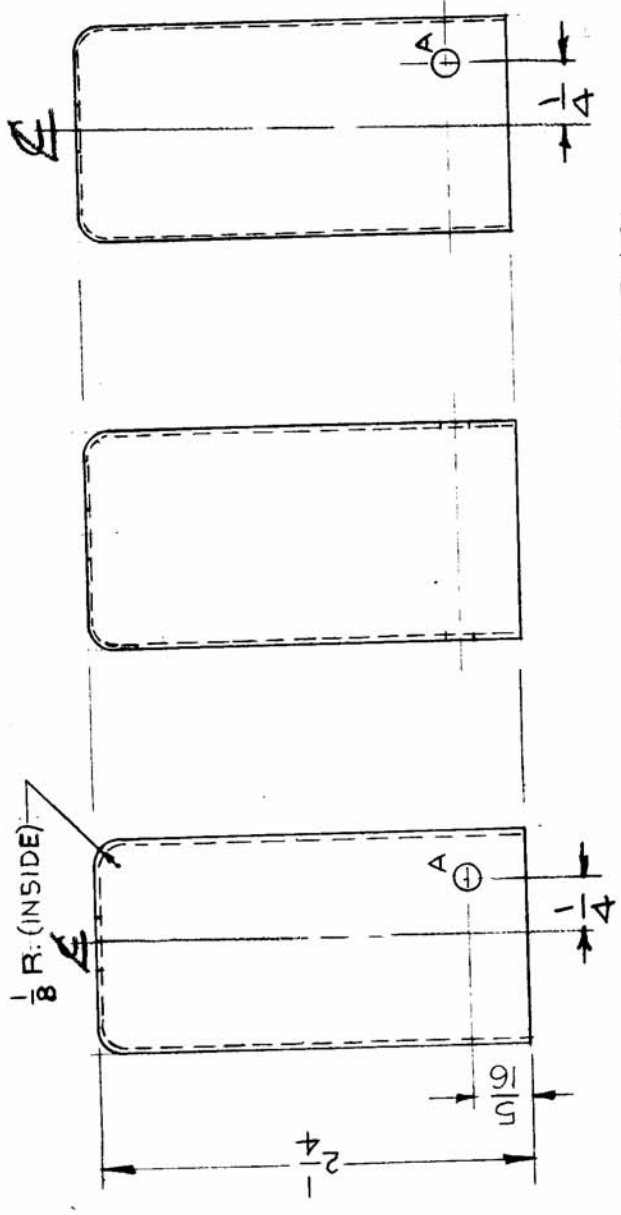
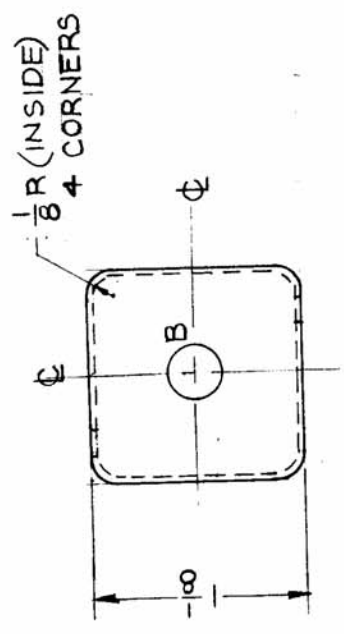

REF FP-161
 REF. ALUMINUM GOODS *

REQ. ITEM		PART NO.	THE TECHNICAL MATERIEL CORP.		SYMBOL
		.0159 THK	MAMARONECK, NEW YORK		
		ALUMINUM	CAN, MACHINING		
ISSUE ITEM		DATE	CH. NO.	DRAFTS	CHECKER
B	1	3-23-61	4509	BM	JCB
A	1	12-9-60	3696	R	JCB
CHANGED FROM		DIM 1/4 WAS 5/16 (Left side of CAN)		ENG. APP.	
TOLERANCES		SCALE:			
DEC. DIM. ±		MAXIMUM ALLOWABLE TOLERANCES HAVE BEEN DETERMINED AND ANY DEVIATIONS WILL BE CAUSE FOR REJECTION.			
FRAC. DIM. ± 1/64		REMOVE ALL BURRS AND SHARP EDGES			
ANGULAR DIM. ±					
TYPE & TEMPER	HEAT TREAT. SPEC.	DRAWN	CHECKED	FINAL APPR VAL	
		CS	JCB	FP-177	B
FINISH & SPEC. NO.		ELEC. DES. APP. MECH. DES. APP.			