

REQ. PER. UNIT	MODEL	USED ON	ES-104
		ASBY. N.	DATE

ASSEMBLE INSTRUCTIONS

1. HALF FILL END SEAL WITH AMPHENOL 53-307 SILICONI COMPOUND, OR EQUIV.
 2. FORCE OVER CABLE.
 3. SLIP CLAMP OVER END SEAL CLAMP TIGHT.
- DEPTH OF HOLE 1 1/2"

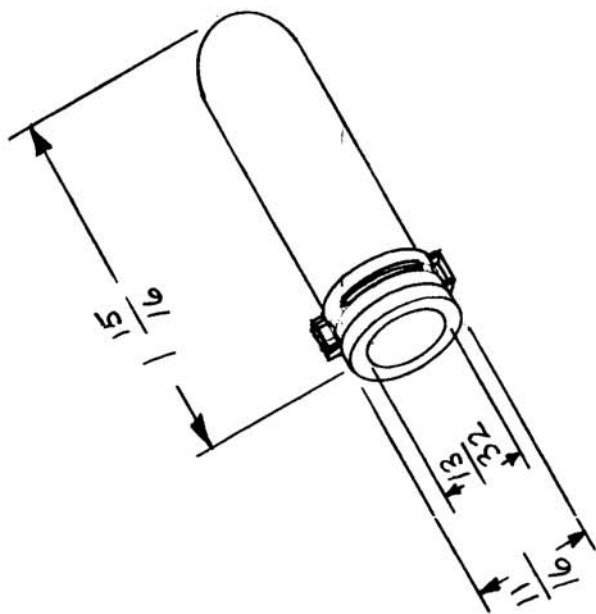

MATERIAL- POLYETHYLENE; MOLDED.
CLAMP- STEEL; RUSTPROOF FINISH.

REQ. ITEM	PART NO.	DESCRIPTION	SYMBOL
		THE TECHNICAL MATERIEL CORP. MAMARONECK, NEW YORK	
		END SEAL, COAXIAL	
		FOR RG-8/U AND RG-11/U CABLE	
		MJT 9-21-61	
		DRAWN	CHECKED
		HEAT TREAT. SPEC.	FINAL APPROVAL
		FINISH & SPEC. NO.	ES-104
		ELEC. DES. APP. MECH. DES. APP.	

ISSUE ITEM	CHANGED FROM	DATE	CH. NO.	DRAFTS	CHECKER	ENG. APP.
TOLERANCES						
SCALE: S-401-70 (15R-201)						
MAXIMUM ALLOWABLE TOLERANCES HAVE BEEN DETERMINED AND ANY DEVIATIONS WILL BE CAUSE FOR REJECTION. REMOVE ALL BURRS AND SHARP EDGES						
DEC. DIM. ±						
FRAC. DIM. ±						
ANGULAR DIM. ±						