

GEAR DATA

NO. OF TEETH ~ 25.
 PITCH DIA. ~ 1.177 $\pm .002$
 OUTER DIA. ~ 1.228 $\pm .004$
 PITCH ~ .1475
 MATERIAL ~ STAINLESS STEEL (303)
 FINISH ~ S104 PASSIVATE (GEAR ONLY)

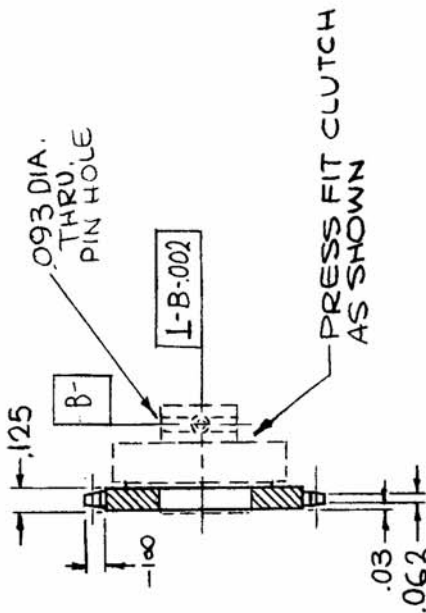

GEAR \emptyset CLUTCH

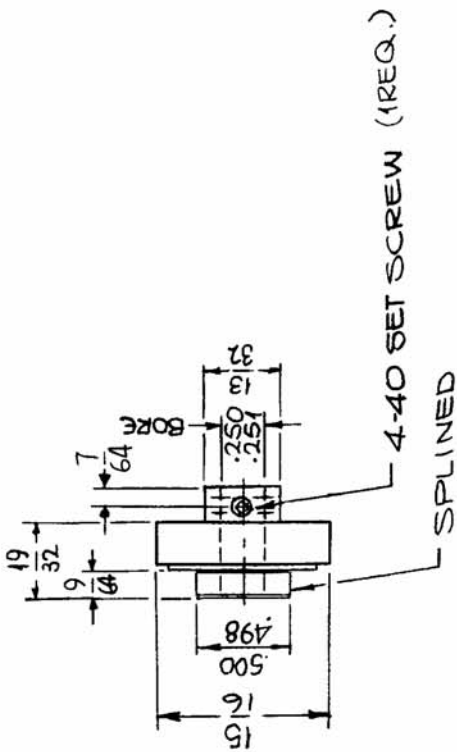

CLUTCH

REQ. PER UNIT	USED ON	DATE
1	ABBY. NO.	3-8-65
	MODEL	
	RFTA-1	

CZ102 \emptyset

REQ. ITEM	PART NO.	F. BUDETTI	DESCRIPTION	SYMBOL
			THE TECHNICAL MATERIEL CORP. MAMARONECK. NEW YORK	
	STOCK SIZE		CLUTCH & GEAR	
	MATERIAL			
	TYPE & TEMPER	SRG	DRAWN	
	HEAT TREAT. SPEC.		CHECKED	
	FINISH & SPEC. NO.		FINAL APPROVAL	
			<i>[Signature]</i>	
			CZ102	\emptyset

ORIGINAL RELEASE FOR PRODUCTION	10-5-65	*	SRG	CHECKER	ENG. APP.
1/64 I.P.E.R.G. 0.93 HOLE ADDED	9-30-65	X1	<i>[Signature]</i>		
EXP. RELEASE	3-8-65	X	SRG		
DESCRIPTION	DATE	CH. NO.	DRAFTS	CHECKER	ENG. APP.
UNLESS OTHERWISE SPECIFIED DIMENSIONS ARE IN INCHES AND INCLUDE CHEMICALLY APPLIED OR PLATED FINISHES					
FRACTIONS	SCALE	1:1			
DECIMALS	CODE	C			
X $\pm .05$	TOLERANCES	HELANDER			
.XX $\pm .01$		D75 A L.H.			
.XXX $\pm .005$					