

REQ. PER UNIT		MODEL		USED ON	
85-7		A2073		ABS'Y. NO. 4-15-64	
DATE		DATE		DATE	
4-15-64		4-15-64		4-15-64	

TMC PART NUMBER	MFG. PART NO.	"A" DIM.	"B" DIM.	"C" DIM.	"D" DIM.	"E" DIM.	"F" SLOT DIM.	"G" DIM.	REMARKS
CU 154-1		1.000	.750	3/8	5/8	5/8	#10	1/2	1 LOOP OPEN END

NOTES:

MATERIAL- ALL PARTS 18% NICKEL SILVER

BAND- .020 THK.-SPRING TEMPER

BRACKET- .032 THK.- 1/4 HARD

LEVER- .032 THK.- 1/4 HARD

SPRING- .061 ROUND- SPRING TEMPER

PIN- .062 ROUND- FULL HARD FINISH- NITRIC ACID DIP IMMUNIZATION.

TOLERANCE- UNLESS OTHERWISE SPECIFIED ± 1/64.

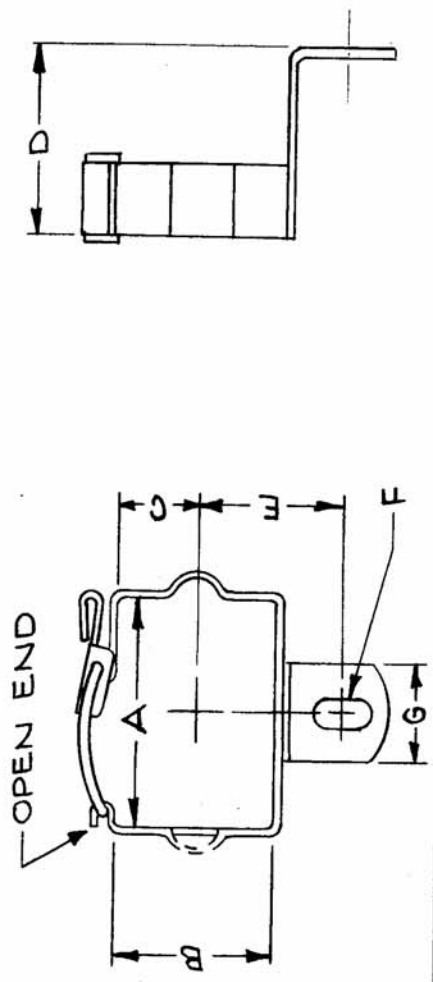

REQ. ITEM	PART NO.	DESCRIPTION	SYMBOL
		O. POSE	
STOCK SIZE		THE TECHNICAL MATERIEL CORP. NEW YORK	
SEE NOTES		RETAINER, ELECTRICAL COMPONENT	
MATERIAL		MAMARONECK. NEW YORK	
TYPE & TEMPER	HEAT TREAT. SPEC.	DRAWN	CHECKED
SEE NOTES		<i>g. l. m.</i>	<i>g. l. m.</i>
FINISH & SPEC. NO.	ENG. APP.	ELEC. DES. APP.	MECH. DES. APP.
8401-105			