

5

4

3

2

1

REVISIONS						
ZONE	LTR	DESCRIPTION	DATE	E.M.N.NO	DRAFT	CHKD APPD
	X	EXP RELEASE	9/16/69		GE	
	A	ADDITIONAL RELEASE				
	A	CHG. P/N ON ITEM 1	3-24-70	20563	GE	EJ EP
	B	DIM 4 7/8 WAS 5 7/16	2-25-70	21693	GOL	EP

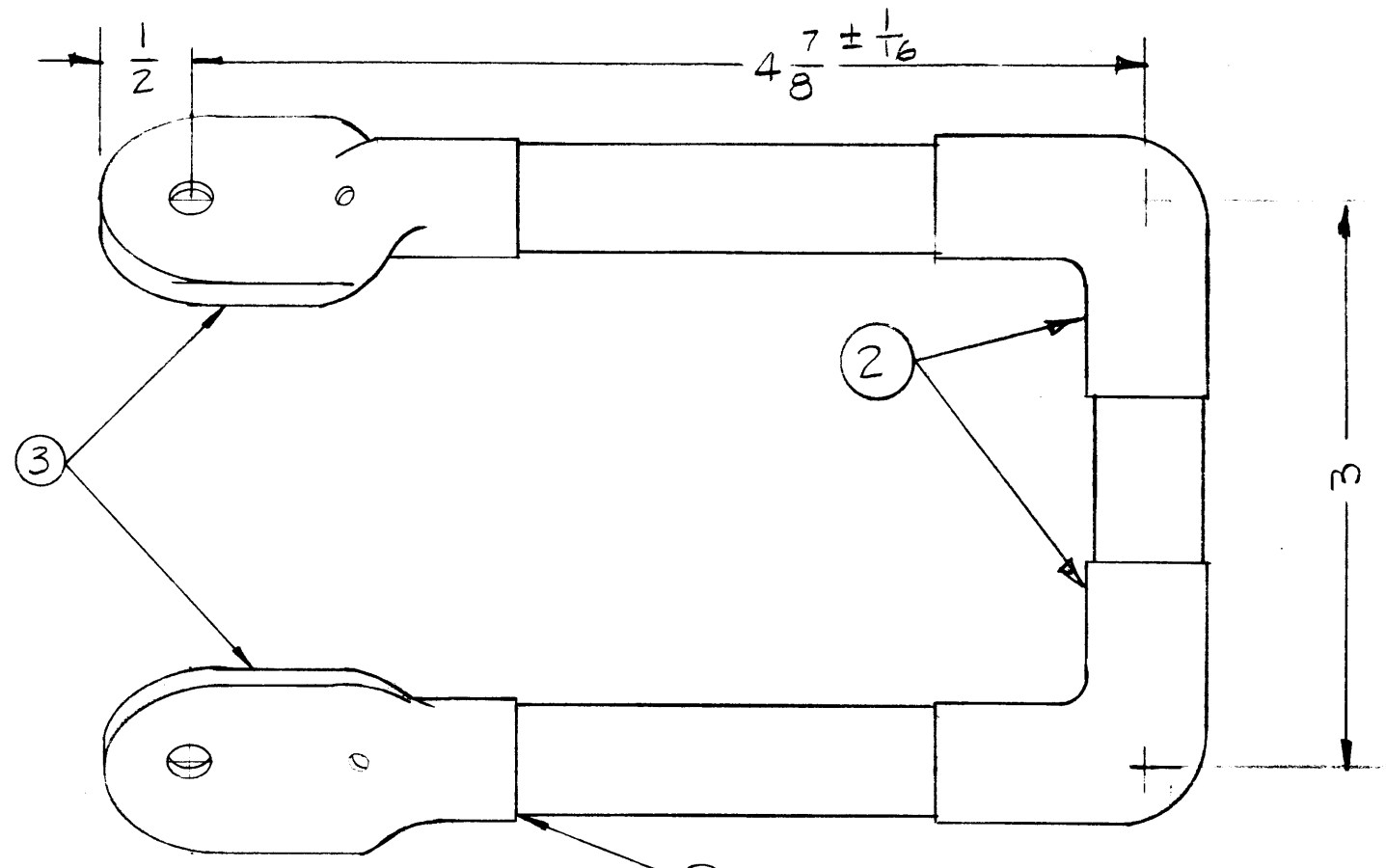
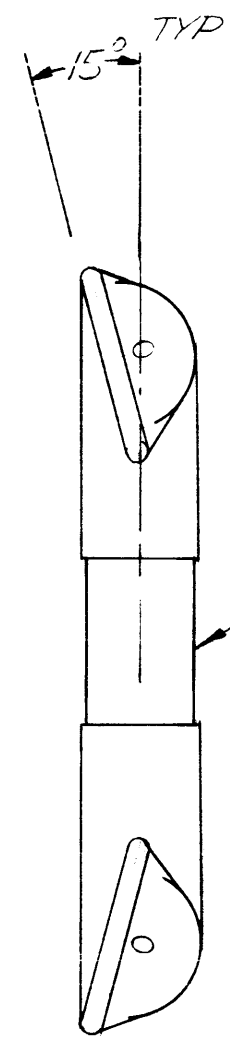

USE IT 4 FOR ALL CONNECTIONS

REQ'D	ITEM	PART NUMBER	DESCRIPTION	SYM.
X	4	BS 101	SOLDER, SILVER	
2	3	TE178-3	LUG	
2	2	PO324	ELBOW PIPING 1/2 COPPER	
X	1	TU-104-8	TUBING HARD TEMPER	

F. BUDETTI		LIST OF MATERIAL	
FINAL APPROVAL MECH. DES. ELECT. DES. CHECKED DRAWN		DATE DATE DATE DATE	
UNLESS OTHERWISE SPECIFIED DIMENSIONS ARE IN INCHES AND INCLUDE CHEMICALLY APPLIED OR PLATED FINISHES		THE TECHNICAL MATERIEL CORP. MAMARONECK, NEW YORK	
DECIMALS .X ± .05 .XX ± .01 .XXX ± .005		FRACTIONS 1/64 ANGLES 0° - 30'	
MATERIAL FINISH S245 SILVER PLATE		COIL, R.F., HIGH FRE.	
SIZE B		CODE IDENT. NO. 82679	
DWG NO. CL-441		ISSUE B	
SCALE NTS		SHEET OF	

1	PALAIOK	AX5084
QTY / UNIT	MODEL USED ON	ASS'Y NO.
APPLICATION		
CODE		
NOTICE TO PERSONS RECEIVING THIS DRAWING THE TECHNICAL MATERIEL CORPORATION claims proprietary right in the material disclosed hereon. This drawing is issued in confidence for engineering information only and may not be reproduced or used to manufacture anything shown hereon without permission from THE TECHNICAL MATERIEL CORPORATION to the user. This drawing is loaned for mutual assistance and is subject to recall at any time.		

5

4

3

2

1