

REVISIONS						
ZONE	LTR	DESCRIPTION	DATE	E.M.N.NO	DRAFT	CHKD
	X	EXPERIMENTAL RELEASE	2/3/69		CV	
	XI	REVISED & UPDATED	3/7/69		CV	
	Ø	ORIGINAL RELEASE FOR PRODUCTION	3/12/69		CV	
	A	RI ADDED	4/7/69		TH	

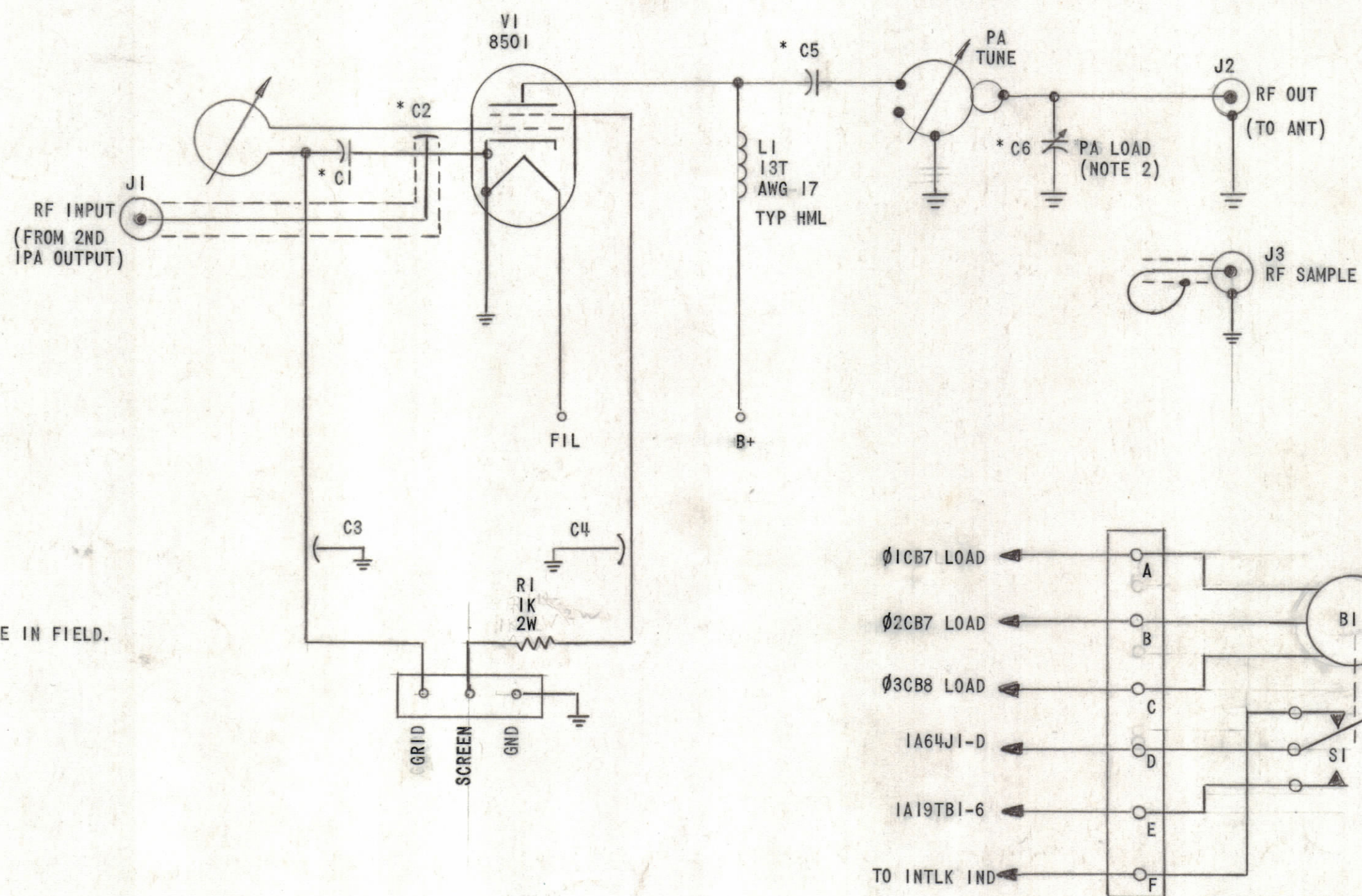

- NOTES:
- * C1, C2, C5, C6 P/O CAVITY ASSEMBLY NOT SERVICEABLE IN FIELD.
 - P.A. LOAD PRE-SET AT FACTORY, DO NOT ADJUST.
 - ALL CAPACITANCE IN pf UNLESS OTHERWISE SPECIFIED.
 - ALL SYMBOLS PREFIXED BY THE FOLLOWING
- | CHAN | PREFIX |
|------|--------|
| 1 | 1A65 |
| 4 | 1A49 |

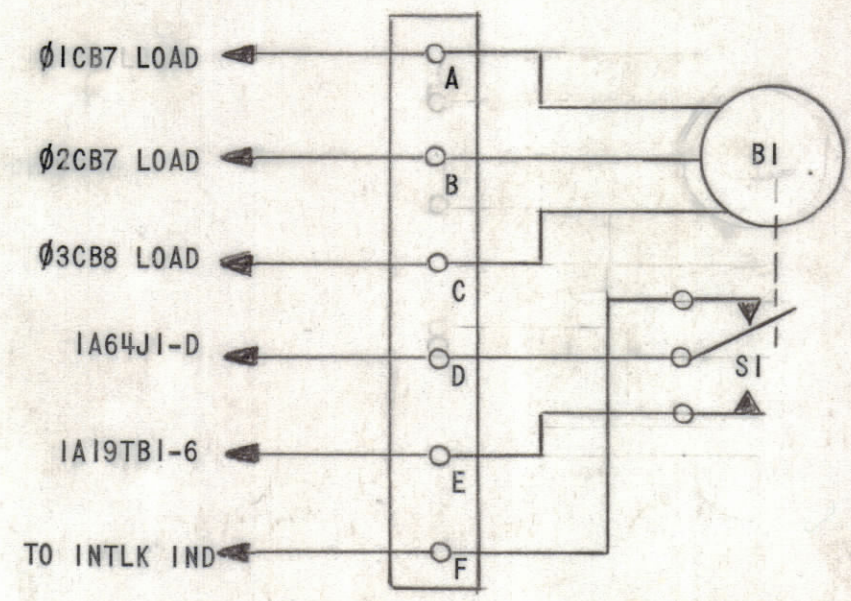

	SPT-3KVHF	AX8090
QTY / UNIT	MODEL USED ON	ASS'Y NO.
APPLICATION		
	CODE	

NOTICE TO PERSONS RECEIVING THIS DRAWING
 THE TECHNICAL MATERIEL CORPORATION claims proprietary right in the material disclosed hereon. This drawing is issued in confidence for engineering information only and may not be reproduced or used to manufacture anything shown hereon without permission from THE TECHNICAL MATERIEL CORPORATION to the user. This drawing is loaned for mutual assistance and is subject to recall at any time.

UNLESS OTHERWISE SPECIFIED DIMENSIONS ARE IN INCHES AND INCLUDE CHEMICALLY APPLIED OR PLATED FINISHES

TOLERANCES ON

DECIMALS	FRACTIONS
.X ± .05	± 1/64
.XX ± .01	ANGLES
.XXX ± .005	± 0° -30'

MATERIAL

FINISH

QTY. REQ.	ITEM	PART NO.	DESCRIPTION	SYMBOL
LIST OF MATERIAL				
FINAL APPROVAL: <i>[Signature]</i> DATE: 3/12/69 MECH. DES. DATE: ELECT. DES. <i>TH</i> DATE: 3-12-69 CHECKED: <i>[Signature]</i> DATE: 3-10-69 DRAWN: <i>CV/TA</i> DATE: 3/7/69				
THE TECHNICAL MATERIEL CORP. MAMARONECK, NEW YORK				
HI BAND PA				
SIZE	CODE IDENT.NO.	DWG NO.	ISSUE	
C	82679	CK 8162	A	
SCALE			SHEET	OF