

ZONE		REVISIONS			DATE	E.M.N.NO	DRAFT	CHKD	APPD
A		CHANGES SUPPLIED BY R. DEPATE			10-23-68			C. Grob	

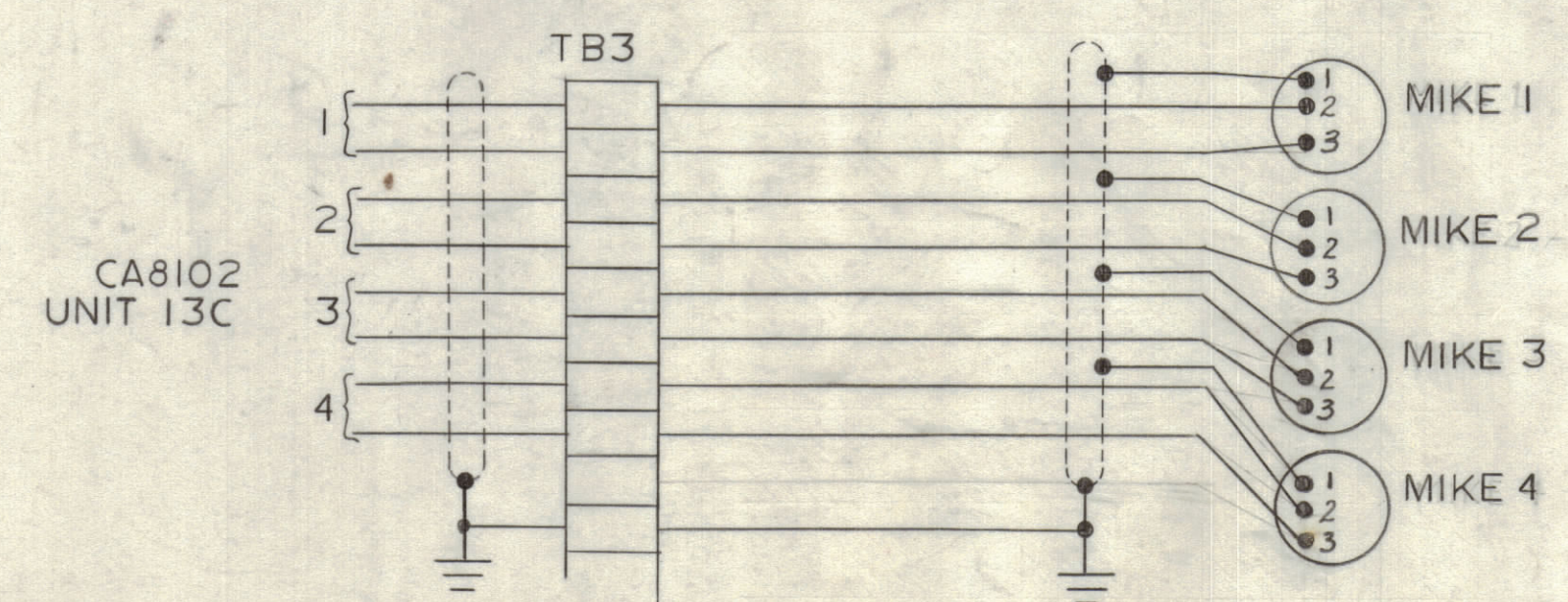
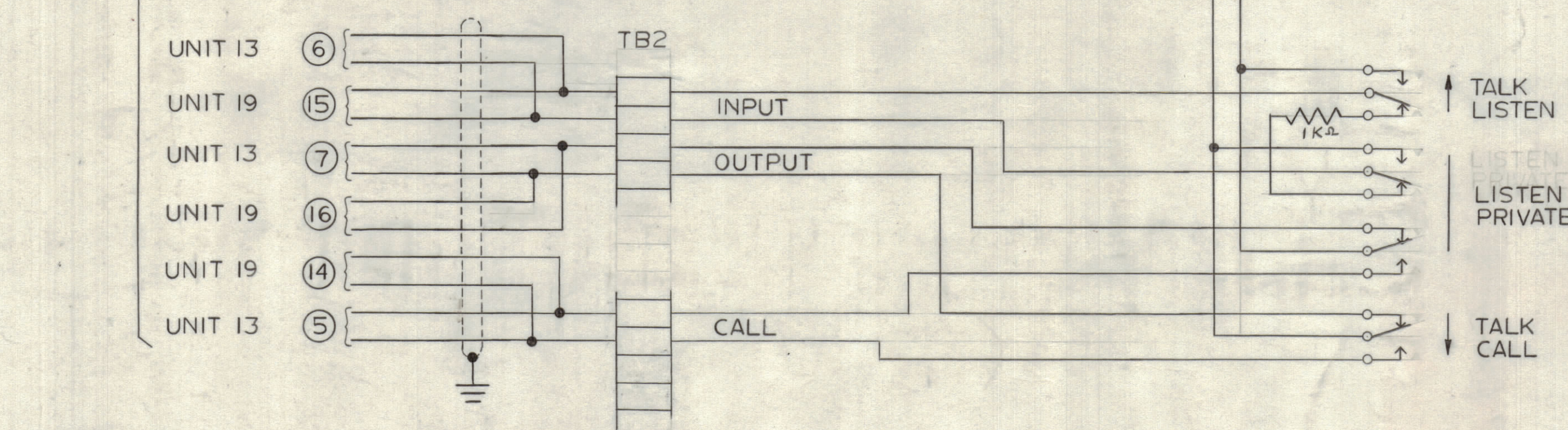
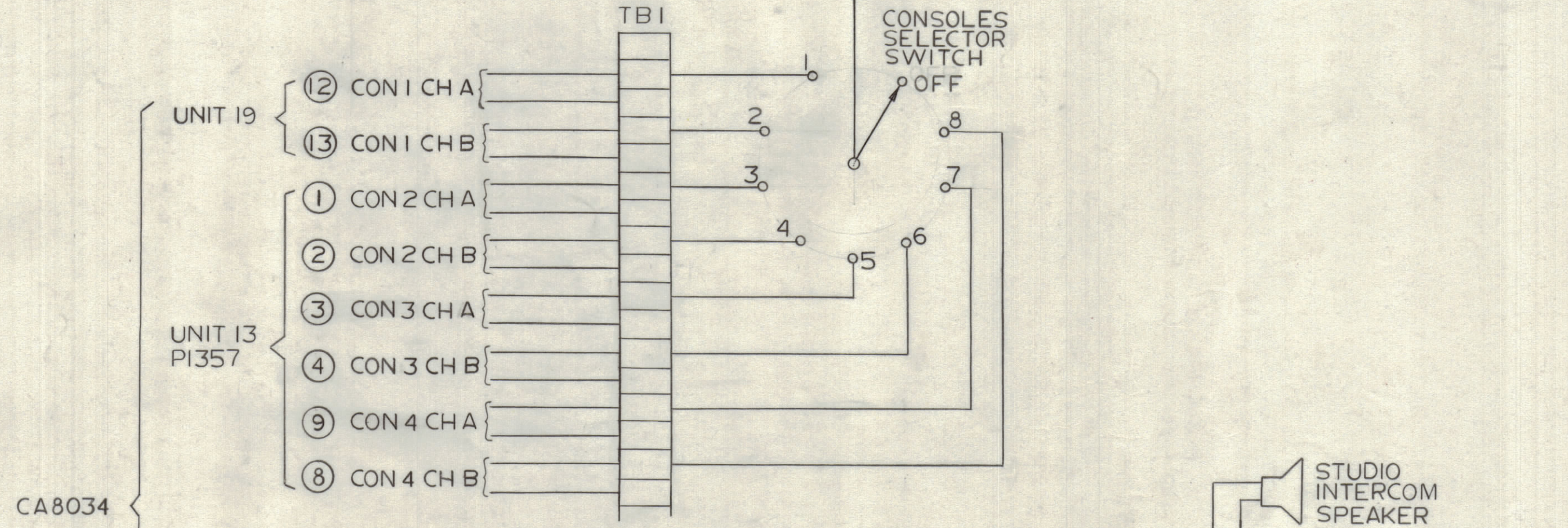
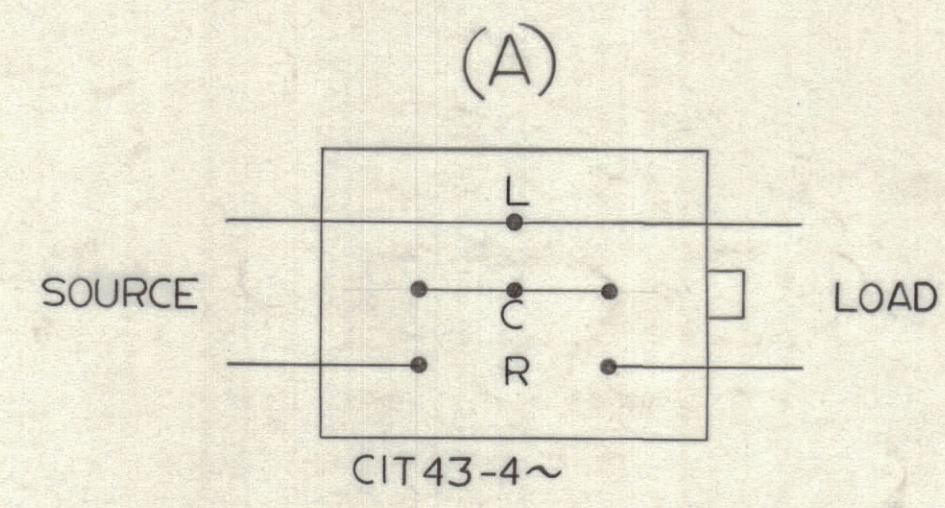
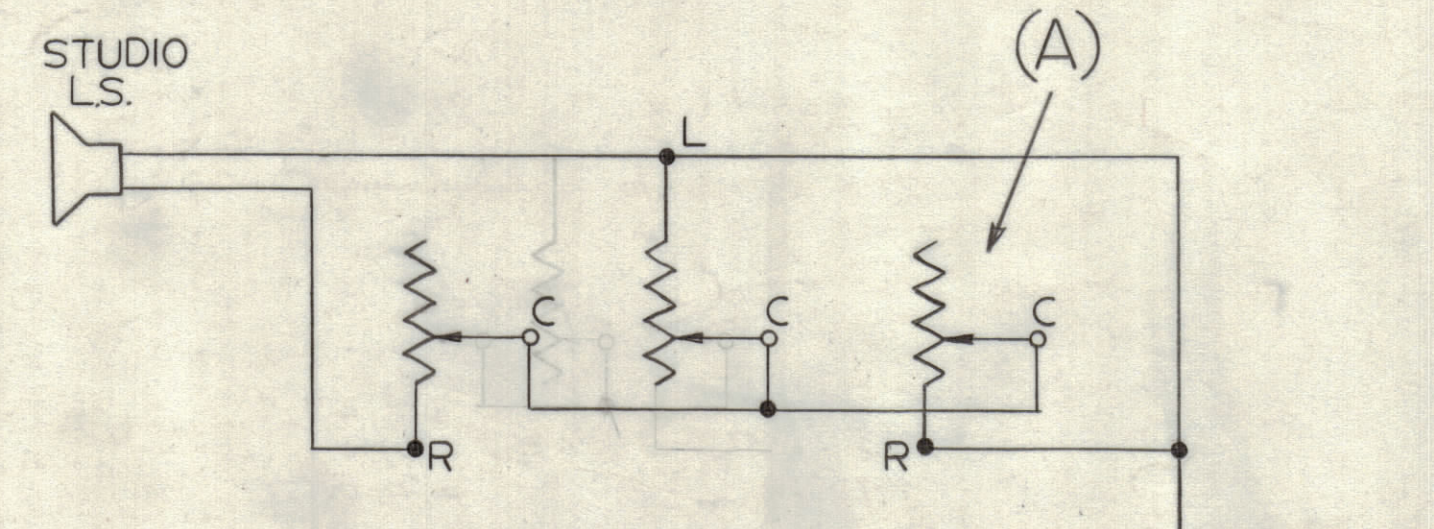

UNIT 22		
QTY / UNIT	MODEL USED ON	ASS'Y NO.
APPLICATION		
CODE		
MATERIAL		
FINISH		

UNLESS OTHERWISE SPECIFIED DIMENSIONS ARE IN INCHES AND INCLUDE CHEMICALLY APPLIED OR PLATED FINISHES	
DECIMALS .X ± .05 .XX ± .01 .XXX ± .005	FRACTIONS ± 1/64 ANGLES ± 0° 30'

QTY. REQ.	ITEM	PART NO.	DESCRIPTION	SYMBOL
LIST OF MATERIAL				
FINAL APPROVAL <i>R. Depate</i>		DATE 8-25-68	THE TECHNICAL MATERIEL CORP. MAMARONECK, NEW YORK <h2 style="margin: 0;">STUDIO CONSOLE SCHEMATIC</h2>	
MECH. DES.		DATE		
ELECT. DES. <i>R. Depate</i>		DATE 8-25-68		
CHECKED <i>Regan</i>		DATE 8-26-68		
DRAWN <i>C. Grob</i>		DATE 8-26-68	SIZE D	CODE IDENT. NO. 82679
			DWG NO. CK8144	ISSUE A
			SCALE	SHEET \ OF \

NOTICE TO PERSONS RECEIVING THIS DRAWING
 THE TECHNICAL MATERIEL CORPORATION claims proprietary right in the material disclosed hereon. This drawing is issued in confidence for engineering information only and may not be reproduced or used to manufacture anything shown hereon without permission from THE TECHNICAL MATERIEL CORPORATION to the user. This drawing is loaned for mutual assistance and is subject to recall at any time.