

REVISIONS						
ZONE	LTR	DESCRIPTION	DATE	E.M.N.NO	DRAFT	CHKD APPD

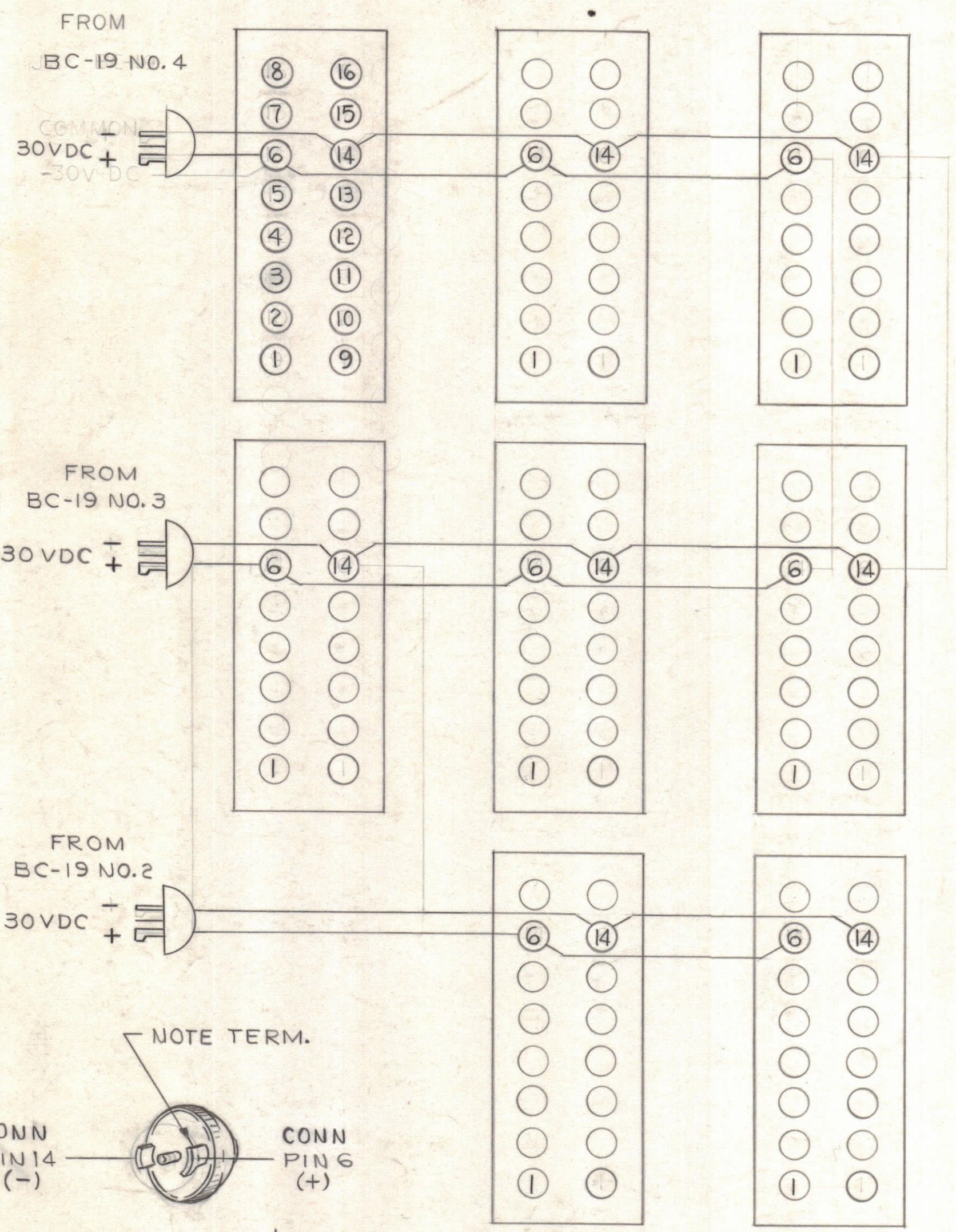

QTY / UNIT	MODEL USED ON	ASS'Y NO.
APPLICATION		
CODE		
<small>NOTICE TO PERSONS RECEIVING THIS DRAWING</small> <small>THE TECHNICAL MATERIEL CORPORATION claims proprietary right in the material disclosed hereon. This drawing is issued in confidence for engineering information only and may not be reproduced or used to manufacture anything shown hereon without permission from THE TECHNICAL MATERIEL CORPORATION to the user. This drawing is loaned for mutual assistance and is subject to recall at any time.</small>		

UNLESS OTHERWISE SPECIFIED DIMENSIONS ARE IN INCHES AND INCLUDE CHEMICALLY APPLIED OR PLATED FINISHES

TOLERANCES ON

DECIMALS	FRACTIONS
.X ± .05	± 1/64
.XX ± .01	ANGLES
.XXX ± .005	± 0° -30'

QTY. REQ.	ITEM	PART NO.	DESCRIPTION	SYMBOL
LIST OF MATERIAL				
FINAL APPROV'D <i>F.O.</i>		DATE 3-20-68	<b>THE TECHNICAL MATERIEL CORP.</b> MAMARONECK, NEW YORK  DC WIRING OF BA-7I AMPLIFIERS	
MECH. DES.		DATE		
ELECT. DES. F. O'DONNELL		DATE 9-25-67		
CHECKED F. O'DONNELL		DATE 10-3-67		
DRAWN C.D. DEAN		DATE 10-2-67		
MATERIAL			SIZE	CODE IDENT. NO.
FINISH			C	82679
			DWG NO.	CK8012
			ISSUE	Ø
			SCALE	SHEET 1 OF 1

CK8012