

REVISIONS					
ZONE	LTR	DESCRIPTION	DATE	E.M.N.O	APPD
	0	ORIGINAL RELEASE FOR PRODUCTION	10/27/76	G.D.L.	G.D.L.

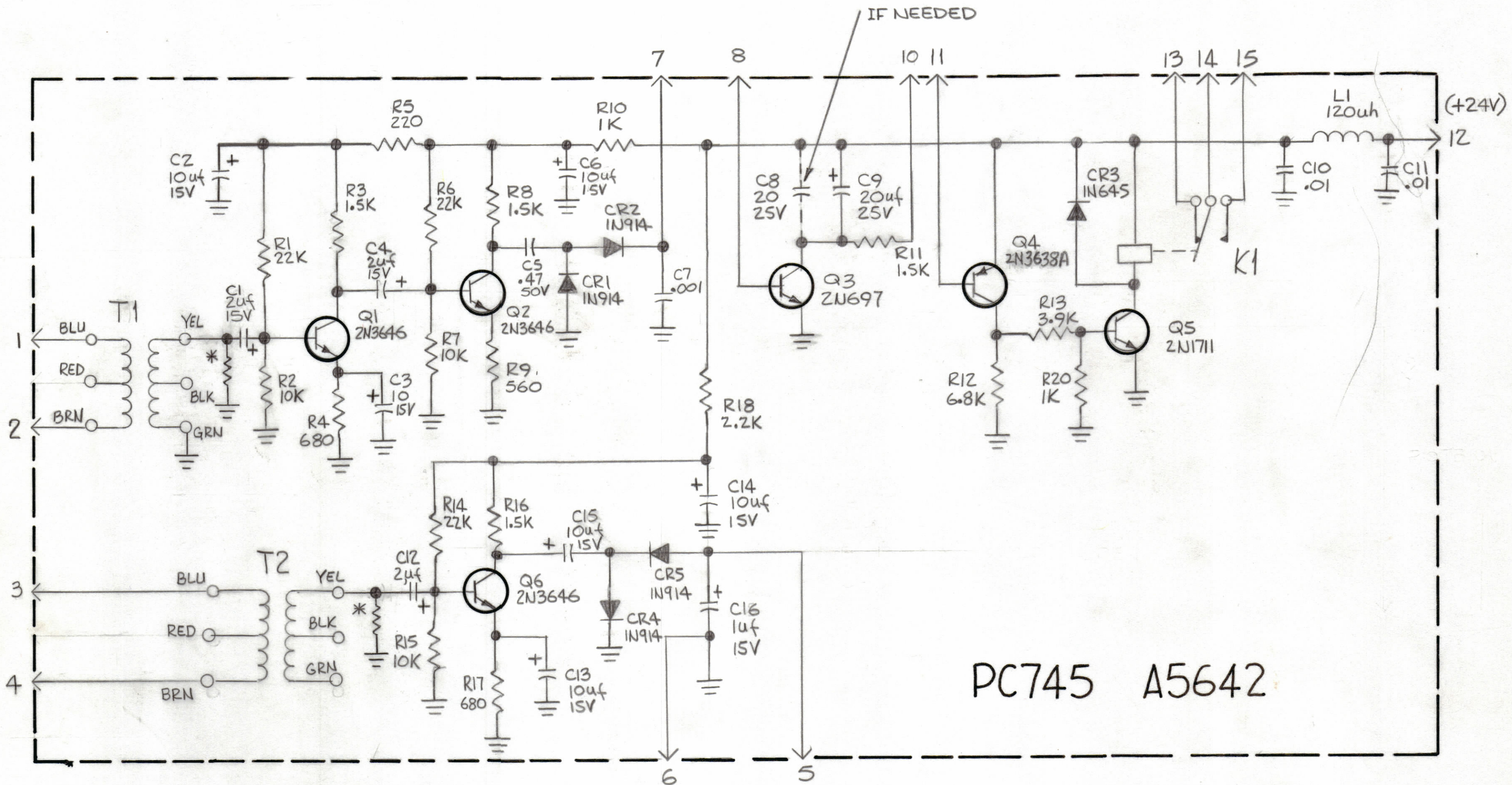

PC745 A5642

\* FACTORY ADJUST (IF NEEDED)

QTY / UNIT	MODEL USED ON	A5642
APPLICATION		
CODE		

NOTICE TO PERSONS RECEIVING THIS DRAWING  
 THE TECHNICAL MATERIEL CORPORATION claims proprietary right in the material disclosed herein. This drawing is issued in confidence for engineering information only and may not be reproduced or used to manufacture anything shown hereon without permission from THE TECHNICAL MATERIEL CORPORATION to the user. This drawing is loaned for mutual assistance and is subject to recall at any time.

UNLESS OTHERWISE SPECIFIED DIMENSIONS ARE IN INCHES AND INCLUDE CHEMICALLY APPLIED OR PLATED FINISHES

TOLERANCES ON

DECIMALS	FRACTIONS
.X ± .05	± 1/64
.XX ± .01	ANGLES
.XXX ± .005	± 0° -30'

QTY. REQ.	ITEM	PART NO.	DESCRIPTION	SYMBOL
LIST OF MATERIAL				
FINAL APPROVAL: <i>[Signature]</i> DATE: 10/25/76 MECH. DES.: <i>[Signature]</i> DATE: 10-25-76 ELECT. DES.: <i>[Signature]</i> DATE: 10/27/76 CHECKED: <i>[Signature]</i> DATE: 10-25-76 DRAWN: GDL, RL DATE:				
<b>THE TECHNICAL MATERIEL CORP.</b> MAMARONECK, NEW YORK <b>SCHEMATIC, DIAGRAM</b> <b>VOX</b>				
SIZE	CODE IDENT. NO.	DWG NO.	ISSUE	
C	82679	CK2134	1	
SCALE				SHEET OF