

5

4

3

2

1

REVISIONS							
E.M.N. NO.	DRAFT	CHKD	ZONE	LTR	DESCRIPTION	DATE	APPROVED
	CL			Ø	ORIGINAL RELEASE FOR PRODUCTION	3/4/75	

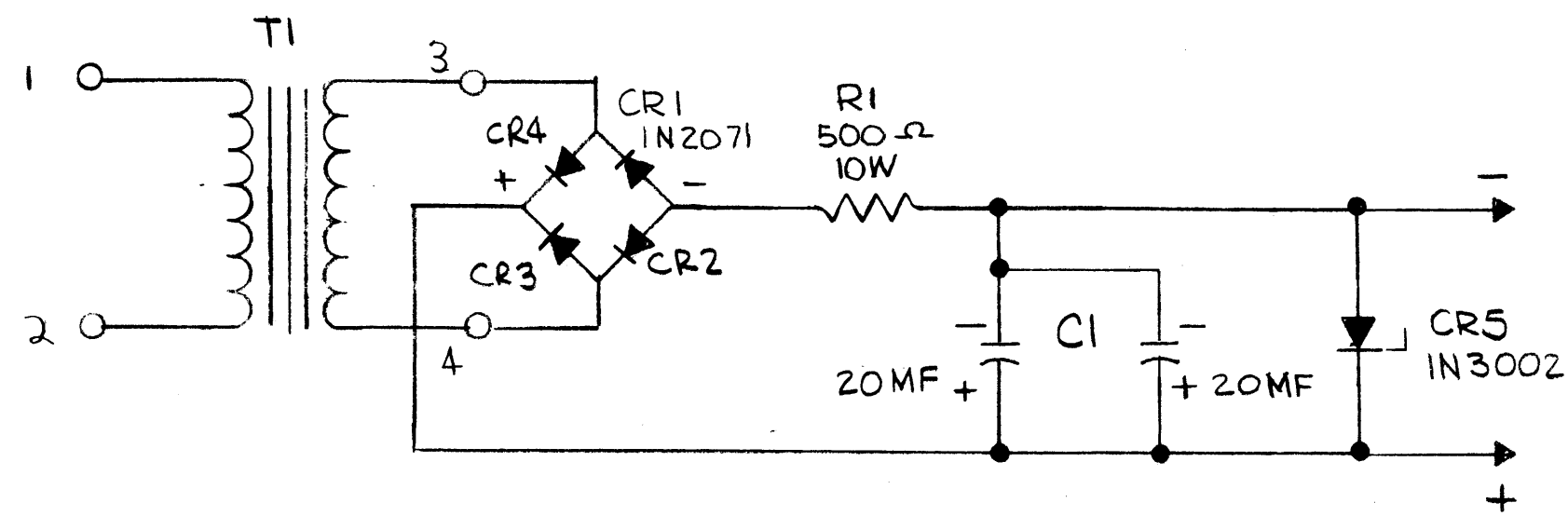

REQ'D	ITEM	PART NUMBER	DESCRIPTION	SYM.
LIST OF MATERIAL				
FINAL APPROVAL <i>[Signature]</i>			DATE 3/4/75	
MECH. DES.			DATE	
ELECT. DES.			DATE	
CHECKED <i>[Signature]</i>			DATE 3-4-75	
DRAWN G.D.L.			DATE 2-8-75	
SIZE	CODE IDENT. NO.	DWG NO.	ISSUE	
B	82679	CK2094	Ø	
SCALE			SHEET OF	

QTY / UNIT	MODEL USED ON	ASS'Y NO.
	KIT 403	AX5191
APPLICATION		
	CODE	
<p>NOTICE TO PERSONS RECEIVING THIS DRAWING THE TECHNICAL MATERIEL CORPORATION claims proprietary right in the material disclosed hereon. This drawing is issued in confidence for engineering information only and may not be reproduced or used to manufacture anything shown hereon without permission from THE TECHNICAL MATERIEL CORPORATION to the user. This drawing is loaned for mutual assistance and is subject to recall at any time.</p>		
FINISH		

UNLESS OTHERWISE SPECIFIED
 DIMENSIONS ARE IN INCHES
 AND INCLUDE CHEMICALLY APPLIED
 OR PLATED FINISHES

DECIMALS FRACTIONS
 .X ± .05 1/64
 .XX ± .01 TOLS. ANGLES
 .XXX ± .005 0° - 30'

THE TECHNICAL MATERIEL CORP.
 MAMARONECK, NEW YORK

SCHEMATIC DIAGRAM
 (-75) NEGATIVE SUPPLY

5

4

3

2

1