

REVISIONS							
E.M.N.O	DRAFT	CHKD	ZONE	LTR	DESCRIPTION	DATE	APPROVED
				X1	UPDATED		
	Q				ORIGINAL RELEASE FOR PRODUCTION	6-16-75	

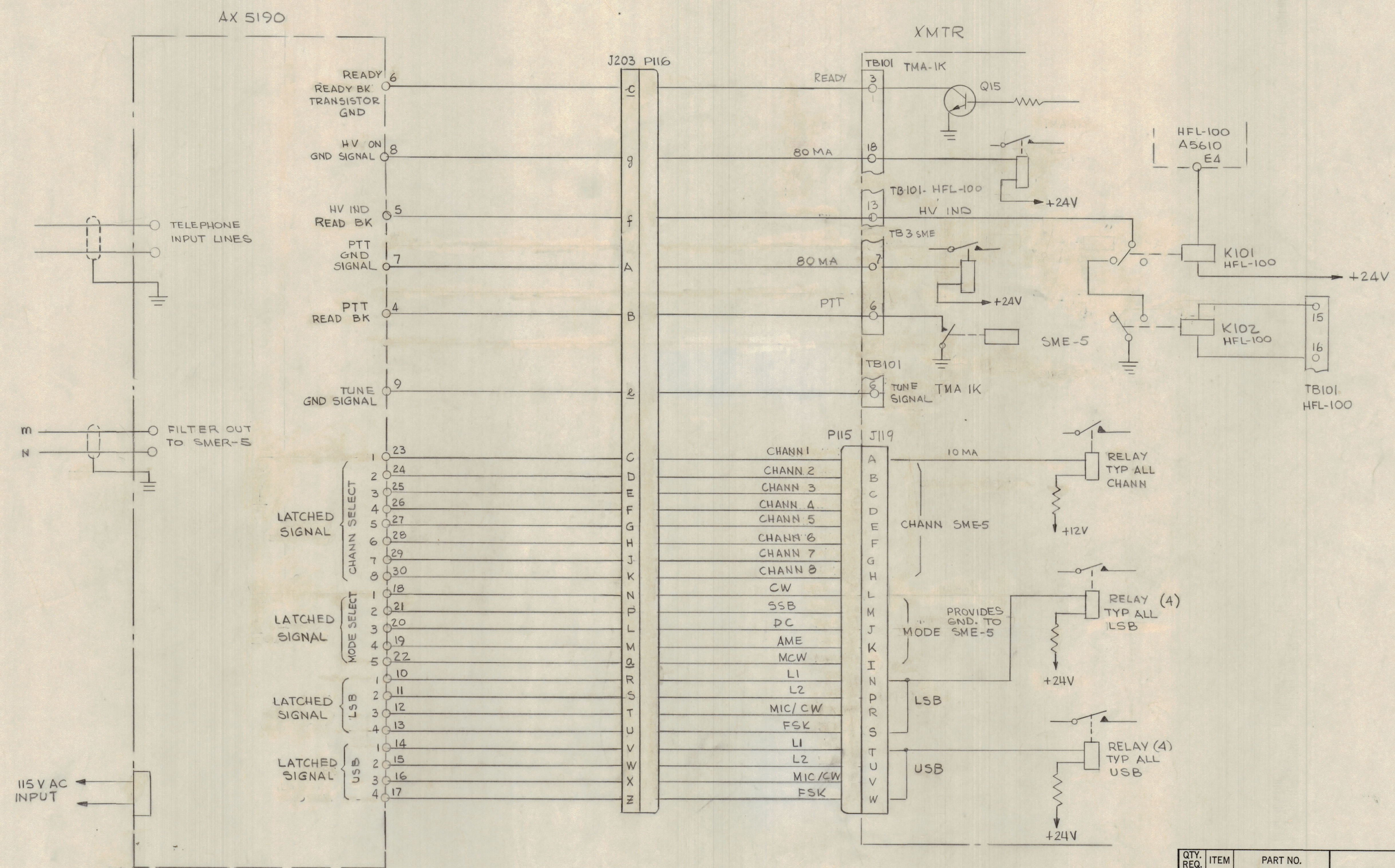

GPTR-1KE4		
QTY / UNIT	MODEL USED ON	ASS'Y NO.
APPLICATION		
CODE		
MATERIAL		
FINISH		

TOLERANCES ON	
DECIMALS	FRACTIONS
.X ± .05	± 1/64
.XX ± .01	ANGLES
.XXX ± .005	± 0° -30'

QTY. REQ.	ITEM	PART NO.	DESCRIPTION	SYMBOL
LIST OF MATERIAL				
FINAL APPROVAL: <i>[Signature]</i> DATE: 7/28/75 MECH. DES. DATE: 5-27-75 ELECT. DES. DATE: 5-27-75 CHECKED: <i>[Signature]</i> DATE: 5-27-75 DRAWN: G. DE LUCA DATE: 1-30-75				
THE TECHNICAL MATERIEL CORP. MAMARONECK, NEW YORK				
INTERCONNECT WIRING DIAGRAM AX 5190				
SIZE	CODE	IDENT NO.	DWG NO.	ISSUE
D	82679	CK 2091		
SCALE		SHEET OF		