

REVISIONS						
ZONE	LTR	DESCRIPTION	DATE	E.M.N.NO	DRAFT	CHKD APPD
	X	EXPERIMENTAL RELEASE	12/11/68		C.V.	
	Ø	ORIG RELEASE FOR PROD	12-11-68	Ø	RG	
	A	REVISED & UPDATED	1-27-69	19270	KD	FB
	B	S2 WAS S1	9/4/69	19590	KH	FB

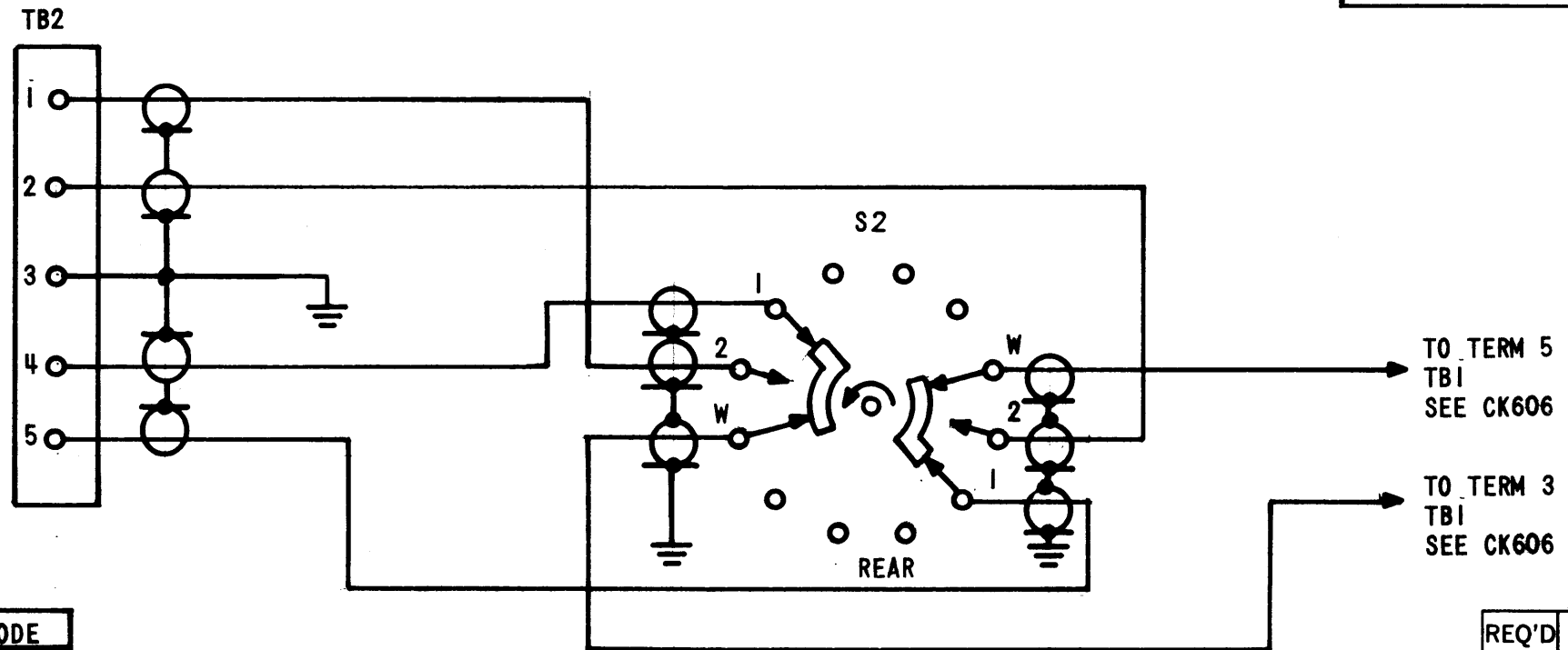
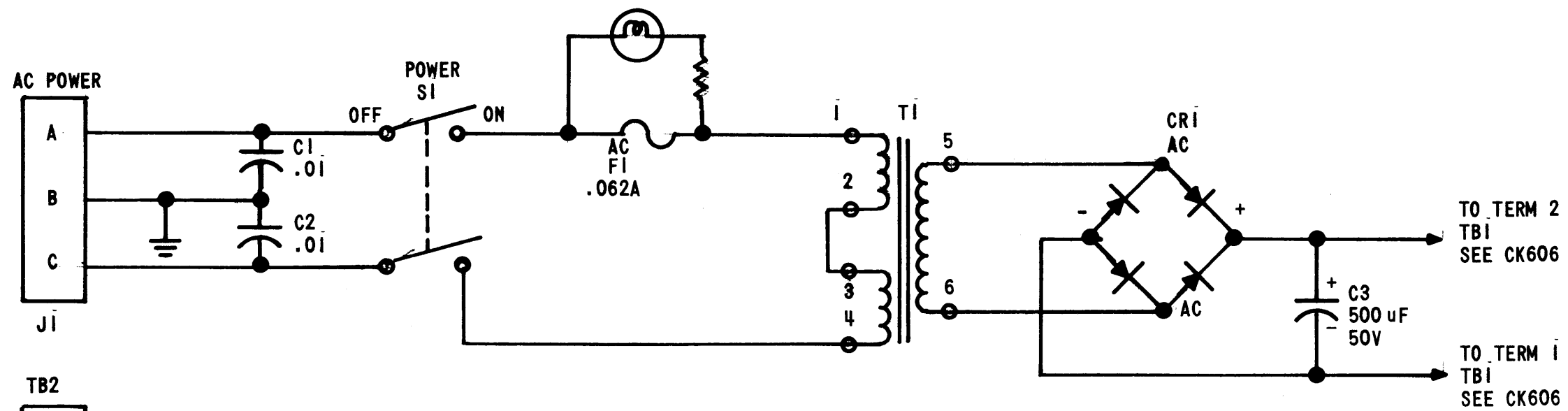

S2 VOX MODE	
POS	FUNCTION
1	USB
2	LSB

QTY / UNIT	MODEL USED ON	ASS'Y NO.
	AP146	
APPLICATION		
	CODE	

NOTICE TO PERSONS RECEIVING THIS DRAWING
 THE TECHNICAL MATERIEL CORPORATION claims proprietary right in the material disclosed hereon. This drawing is issued in confidence for engineering information only and may not be reproduced or used to manufacture anything shown hereon without permission from THE TECHNICAL MATERIEL CORPORATION to the user. This drawing is loaned for mutual assistance and is subject to recall at any time.

UNLESS OTHERWISE SPECIFIED
 DIMENSIONS ARE IN INCHES
 AND INCLUDE CHEMICALLY APPLIED
 OR PLATED FINISHES

DECIMALS: .X ± .05, .XX ± .01, .XXX ± .005
 FRACTIONS: 1/64
 TOLS. ANGLES: 0° .30'

MATERIAL
 FINISH

REQ'D	ITEM	PART NUMBER	DESCRIPTION	SYM.
BUDETTI LIST OF MATERIAL				
FINAL APPROVAL			DATE	
MECH. DES.			DATE	
ELECT. DES.			DATE	
CHECKED			DATE	
DRAWN			DATE	
SIZE	CODE IDENT. NO.	DWG NO.	ISSUE	
B	82679	CK 1588	B	
SCALE		SHEET OF		

THE TECHNICAL MATERIEL CORP.
 MAMARONECK, NEW YORK

DIAGRAM, SCHEMATIC
 AP 146