

A
CK1208

REVISIONS

SYM	DESCRIPTION	DATE	E.M.N. NO.	DRAFT	CHKD	APPD
X	EXP. RELEASE	9-3-64	X	JBC	JLQ	M
X1	P9000, P9001 WERE J9003, J9004, CP9000 - CP9001 ADDED.	10-4-66	X1	<i>[Signature]</i>	<i>[Signature]</i>	<i>[Signature]</i>
X2	DC 9000 & R9000 DELETED FROM F9000	1-17-67	X2	<i>[Signature]</i>	<i>[Signature]</i>	<i>[Signature]</i>
X3	GRD ADDED ON J9001 & J9002	2-21-67	X3	<i>[Signature]</i>	<i>[Signature]</i>	<i>[Signature]</i>
Ø	ORIGINAL RELEASE FOR PRODUCTION	2/23/67	Ø	CV		
A	.5A TO F9000 ADDED	12/27/68	19138	KH.	<i>[Signature]</i>	FB

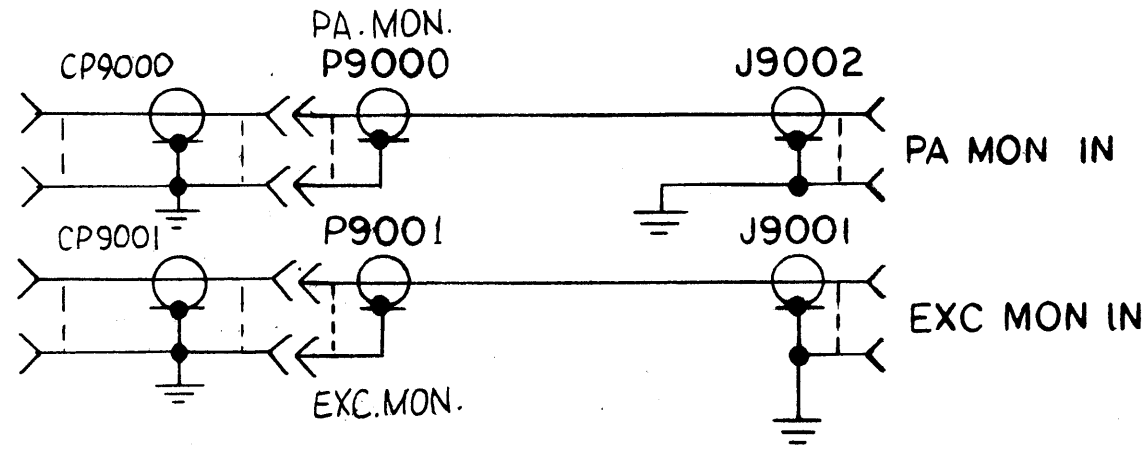
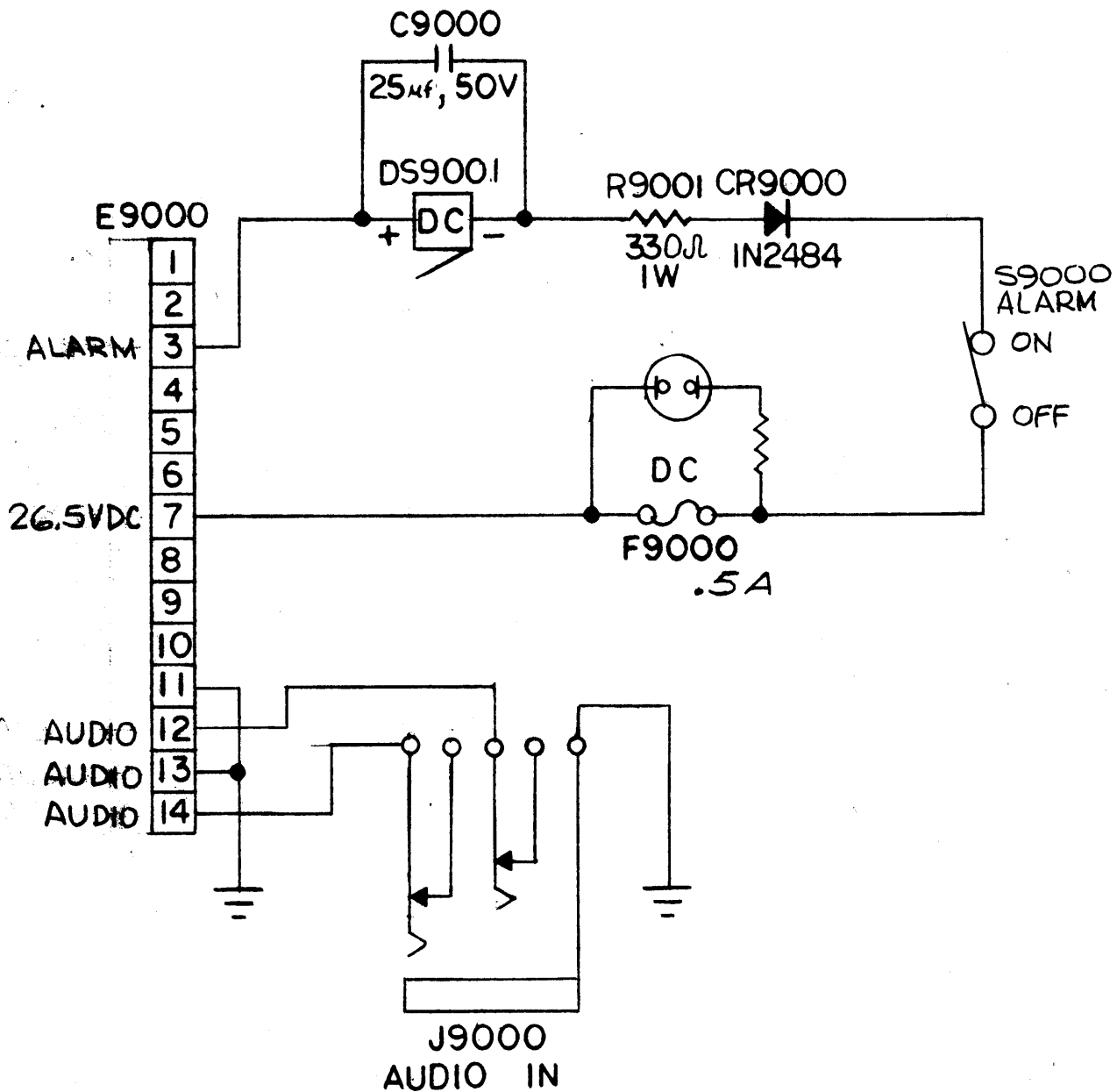

NOTES

1	AX647	
Q'TY./UNIT	MODEL USED ON	ASS'Y. NO.
SCALE	CODE	

THE CONTENTS OF THIS DRAWING ARE THE EXCLUSIVE PROPERTY OF THE TECHNICAL MATERIEL CORP. ITS UNAUTHORIZED USE OR REPRODUCTION IN WHOLE OR IN PART IS STRICTLY FORBIDDEN.

REQ'D.	ITEM	PART NUMBER	DESCRIPTION	SYMBOL
F BUDETTI LIST OF MATERIAL				
MATERIAL		THE TECHNICAL MATERIEL CORP. MAMARONECK, NEW YORK		
FINISH		TITLE SCHEMATIC, MONITOR PANEL		
UNLESS OTHERWISE SPECIFIED DIMENSIONS ARE IN INCHES AND INCLUDE CHEMICALLY APPLIED OR PLATED FINISHES		DRAWN JBC	DATE 9-1-66	FINAL APPROVAL <i>[Signature]</i>
DECIMALS .X ± .05 .XX ± .01 .XXX ± .005		CHECKED	DATE	
FRACTIONS ± 1/64 ANGLES ± 0° 30'		ELECT. DES. <i>[Signature]</i>	DATE	
TOLERANCES		MECH. DES.	DATE	
				CK1208
				SHEET

M/K JBC