

IF IT IS FOUND DESIRABLE TO CHANGE ANY TOLERANCE OR OTHER DETAIL SPECIFIED ON THIS DRAWING NOTIFY THE PURCHASER PROMPTLY.

MAXIMUM ALLOWABLE TOLERANCES HAVE BEEN DETERMINED AND DEVIATIONS WILL BE CAUSE FOR REJECTION. REMOVE ALL BURRS AND SHARP EDGES

**NOTICE TO PERSONS RECEIVING THIS DRAWING**

THE TECHNICAL MATERIEL CORPORATION claims proprietary right in the material disclosed hereon. This drawing is issued in confidence for engineering information only and may not be reproduced or used to manufacture anything shown hereon without permission from THE TECHNICAL MATERIEL CORPORATION to the user. This drawing is loaned for mutual assistance and is subject to recall at any time.

Property of:  
THE TECHNICAL MATERIEL CORPORATION  
MAMARONECK, NEW YORK

NOTE: RIGHT HARNESSSES FOR RACKS  
A18 + A19 (DRAWING Nos CK-10197  
& CK-10199) ARE IDENTICAL TO THIS.

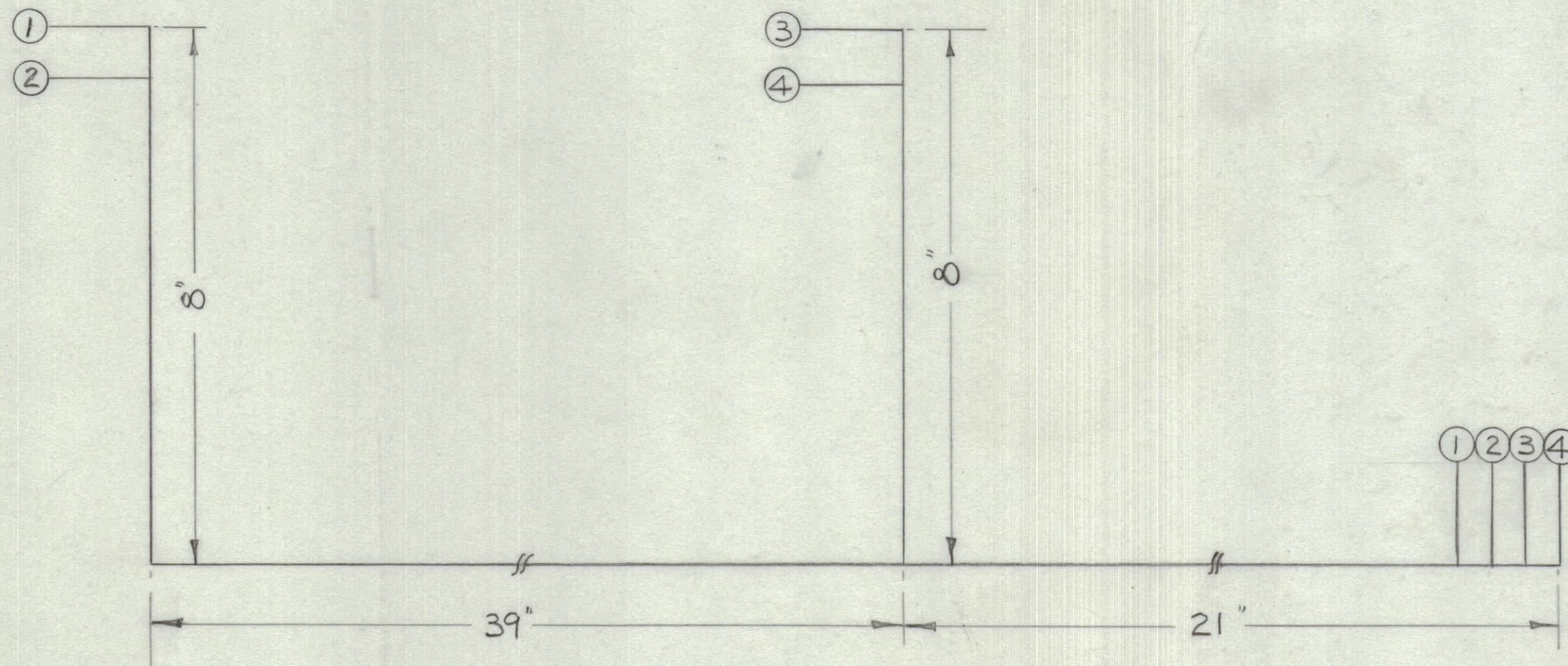

CK-10200

1	4	31" WL - JANC76A - UNSH. WH.
1	3	31" " - " - " R
1	2	70" " - " - " WH.
1	1	70" WL - JANC76A - UNSH. R.

REQ.	ITEM	PART NO.	DESCRIPTION	SYMBOL
<b>TMC (Canada) LIMITED</b> OTTAWA ONTARIO				
RIGHT HARNESS FOR RACK B1				
MATERIAL		WEIGHT PER PC.		
TYPE & TEMPER		ECL		
HEAT TREAT. SPEC.		DRAWN		
FINISH & SPEC. NO.		ELEC. DES. APP.		
		MECH. DES. APP.		
		CHECKED		
		FINAL APPROVAL		
		CK-10200		

ISSUE	ITEM	CHANGED FROM	DATE	CN. NO.	DRAFTS	CHECKER	ENG. APP.
TOLERANCES		SCALE:					
ALL OTHERS	DEC. DIM. ± FRAC. DIM. ± ANGULAR DIM. ±	DRILL, PUNCH, COMMERCIAL STOCK SIZES AND MANUFACTURERS TOLERANCES ARE NOT INCLUDED.					

MODEL	PROJECT NO.	ASS'Y. NO.	DATE
			12/12/57
USED ON			