

NOTE TO PURCHASER REVIEWING THIS DRAWING

IF IT IS FOUND DESIRABLE TO CHANGE ANY TOLERANCE OR OTHER DETAIL SPECIFIED ON THIS DRAWING NOTIFY THE PURCHASER PROMPTLY.

MAXIMUM ALLOWABLE TOLERANCES HAVE BEEN DETERMINED AND DEVIATIONS WILL BE CAUSE FOR REJECTION. REMOVE ALL BURRS AND SHARP EDGES

THE TECHNICAL MATERIEL CORPORATION claims proprietary right in the material disclosed hereon. This drawing is issued in confidence for engineering information only and may not be reproduced or used to manufacture anything shown hereon without permission from THE TECHNICAL MATERIEL CORPORATION to the user. This drawing is loaned for mutual assistance and is subject to recall at any time.

Property of:  
THE TECHNICAL MATERIEL CORPORATION  
MAMARONECK, NEW YORK

CK-152

TB-5

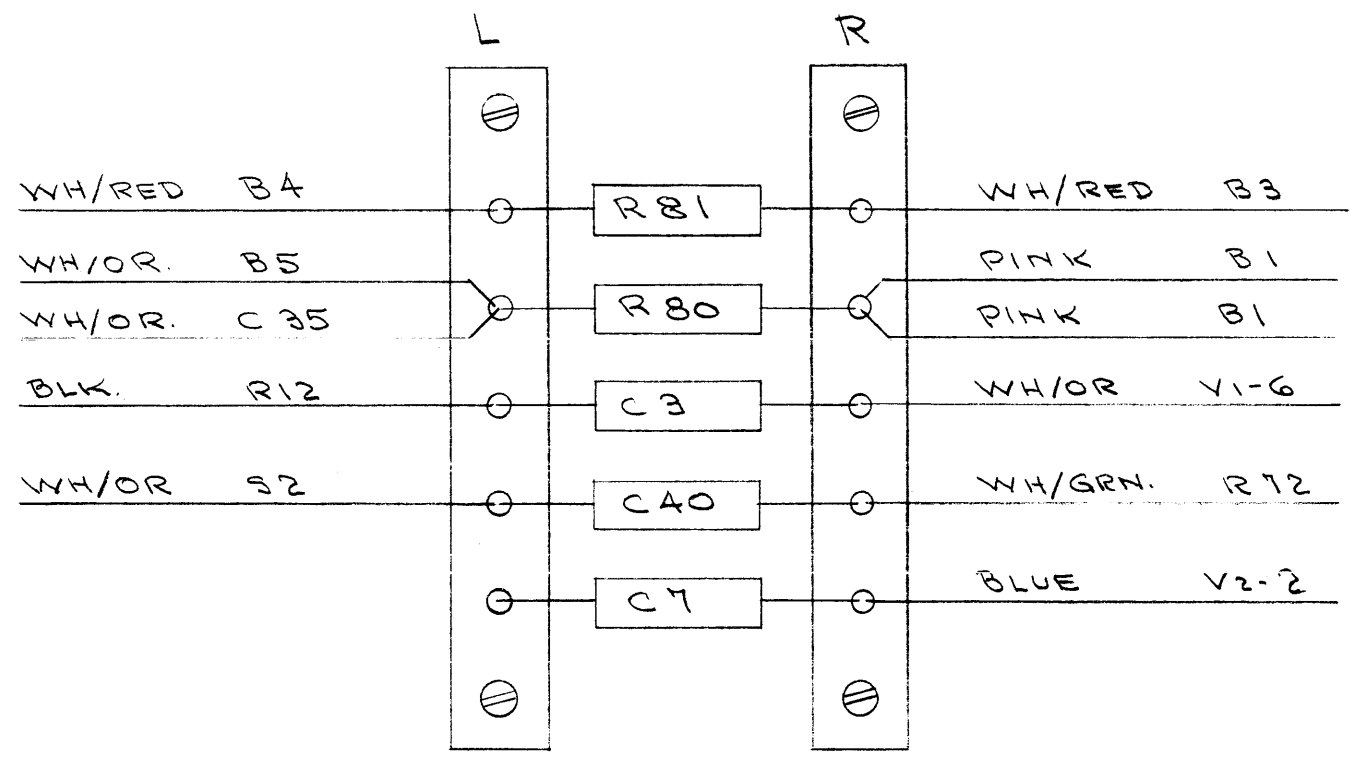

No.	FROM	TO	COLOR	LENGTH	STRIP
A1	R-C3	V1-6	WH/OR	4 1/2	1/2
A2	R-C7	V2-2	BLUE	5	1/2

TB 6

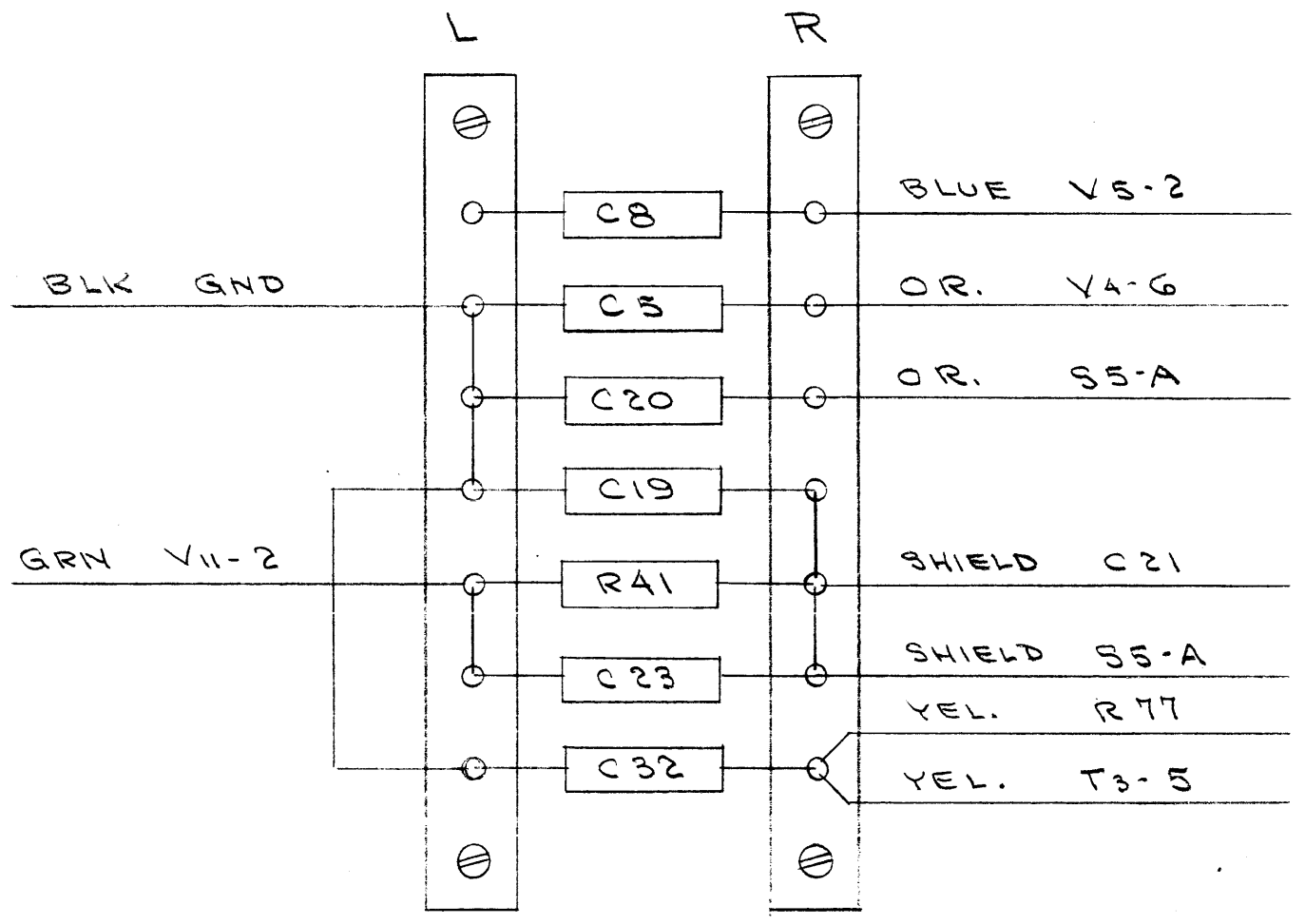

No	FROM	TO	COLOR	LENGTH	STRIP
A3	RC-8	V5-2	BLUE	5 3/4	1/2
A4	RC-5	V4-6	WH/OR		1/2

#	#	REDDRAWN - NO CHANGE	DATE	CN. NO.	DRAFTS	CHECKER	ENG. APP.

TOLERANCES		SCALE:	
ALL OTHERS	DEC. DIM. ± FRAC. DIM. ± ANGULAR DIM. ±	DRILL, PUNCH, COMMERCIAL STOCK SIZES AND MANUFACTURERS TOLERANCES ARE NOT INCLUDED.	

REQ. PER UNIT	MODEL	PROJECT NO.	ASS'Y. NO.	DATE
	CFA			11-30-54

REQ.	ITEM	PART NO.	DESCRIPTION	SYMBOL
			THE TECHNICAL MATERIEL CORP. MAMARONECK, NEW YORK	
			WIRING DIAGRAM TB-5 & 6	
			CFA	
			CDD 11/30/54	
			DRAWN	
			ELEC. DES. APP.	
			CHECKED	
			FINAL APPROVAL	
			CK-152	