

CH 300 Ø

REQ. PER UNIT	1
MODEL	GPT-200K
USED ON	AP-112
DATE	5-19-64

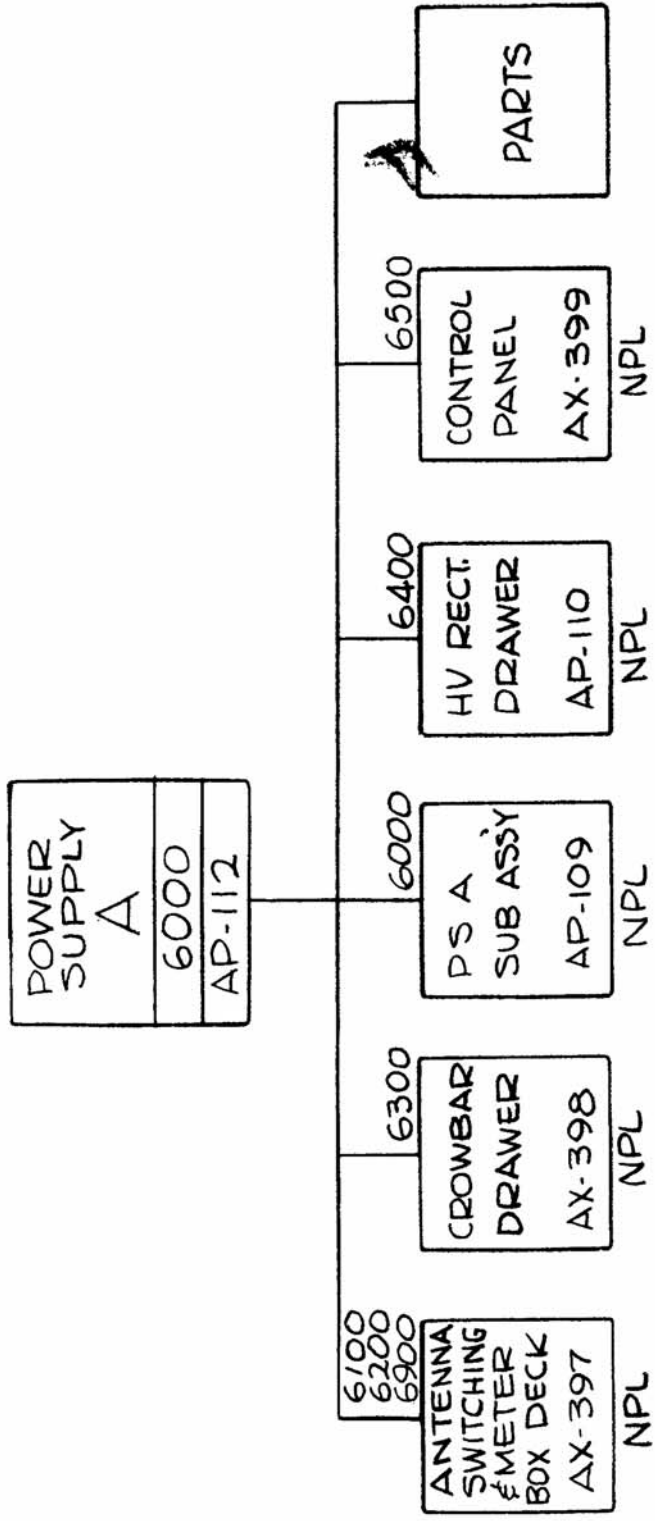

REQ. ITEM	PART NO.	F. BUDETTI	DESCRIPTION	SYMBOL
			THE TECHNICAL MATERIEL CORP. MAMARONECK. NEW YORK	
			CHART, UNIT BREAKDOWN	
			AP-112	
			SRG @ 1-7-65	
			DRAWN	
			CHECKED	
			TYPE & TEMPER	
			HEAT TREAT. SPEC.	
			MATERIAL	
			FINISH & SPEC. NO.	
			ENG. APP.	
			CHECKER	
			DRAFTS	
			CH. NO.	
			DATE	
			1.8.65	
			SCALE	
			UNLESS OTHERWISE SPECIFIED	
			DIMENSIONS ARE IN INCHES AND INCLUDE	
			CHEMICALLY APPLIED OR PLATED FINISHES	
			TOLERANCES	
			DECIMALS	
			.X ± .05	
			.XX ± .01	
			.XXX ± .005	
			FRACTIONS	
			± 1/64	
			ANGLES	
			± 0° 30'	
			CODE	
			ORIGINAL RELEASE	
			AP-112	
			SRG @ 1-7-65	
			DRAWN	
			CHECKED	
			TYPE & TEMPER	
			HEAT TREAT. SPEC.	
			MATERIAL	
			FINISH & SPEC. NO.	
			ENG. APP.	
			CHECKER	
			DRAFTS	
			CH. NO.	
			DATE	
			1.8.65	
			SCALE	
			UNLESS OTHERWISE SPECIFIED	
			DIMENSIONS ARE IN INCHES AND INCLUDE	
			CHEMICALLY APPLIED OR PLATED FINISHES	
			TOLERANCES	
			DECIMALS	
			.X ± .05	
			.XX ± .01	
			.XXX ± .005	
			FRACTIONS	
			± 1/64	
			ANGLES	
			± 0° 30'	
			CODE	
			ORIGINAL RELEASE	
			AP-112	
			SRG @ 1-7-65	
			DRAWN	
			CHECKED	
			TYPE & TEMPER	
			HEAT TREAT. SPEC.	
			MATERIAL	
			FINISH & SPEC. NO.	
			ENG. APP.	
			CHECKER	
			DRAFTS	
			CH. NO.	
			DATE	
			1.8.65	
			SCALE	
			UNLESS OTHERWISE SPECIFIED	
			DIMENSIONS ARE IN INCHES AND INCLUDE	
			CHEMICALLY APPLIED OR PLATED FINISHES	
			TOLERANCES	
			DECIMALS	
			.X ± .05	
			.XX ± .01	
			.XXX ± .005	
			FRACTIONS	
			± 1/64	
			ANGLES	
			± 0° 30'	
			CODE	
			ORIGINAL RELEASE	
			AP-112	
			SRG @ 1-7-65	
			DRAWN	
			CHECKED	
			TYPE & TEMPER	
			HEAT TREAT. SPEC.	
			MATERIAL	
			FINISH & SPEC. NO.	
			ENG. APP.	
			CHECKER	
			DRAFTS	
			CH. NO.	
			DATE	
			1.8.65	
			SCALE	
			UNLESS OTHERWISE SPECIFIED	
			DIMENSIONS ARE IN INCHES AND INCLUDE	
			CHEMICALLY APPLIED OR PLATED FINISHES	
			TOLERANCES	
			DECIMALS	
			.X ± .05	
			.XX ± .01	
			.XXX ± .005	
			FRACTIONS	
			± 1/64	
			ANGLES	
			± 0° 30'	
			CODE	
			ORIGINAL RELEASE	
			AP-112	
			SRG @ 1-7-65	
			DRAWN	
			CHECKED	
			TYPE & TEMPER	
			HEAT TREAT. SPEC.	
			MATERIAL	
			FINISH & SPEC. NO.	
			ENG. APP.	
			CHECKER	
			DRAFTS	
			CH. NO.	
			DATE	
			1.8.65	
			SCALE	
			UNLESS OTHERWISE SPECIFIED	
			DIMENSIONS ARE IN INCHES AND INCLUDE	
			CHEMICALLY APPLIED OR PLATED FINISHES	
			TOLERANCES	
			DECIMALS	
			.X ± .05	
			.XX ± .01	
			.XXX ± .005	
			FRACTIONS	
			± 1/64	
			ANGLES	
			± 0° 30'	
			CODE	
			ORIGINAL RELEASE	
			AP-112	
			SRG @ 1-7-65	
			DRAWN	
			CHECKED	
			TYPE & TEMPER	
			HEAT TREAT. SPEC.	
			MATERIAL	
			FINISH & SPEC. NO.	
			ENG. APP.	
			CHECKER	
			DRAFTS	
			CH. NO.	
			DATE	
			1.8.65	
			SCALE	
			UNLESS OTHERWISE SPECIFIED	
			DIMENSIONS ARE IN INCHES AND INCLUDE	
			CHEMICALLY APPLIED OR PLATED FINISHES	
			TOLERANCES	
			DECIMALS	
			.X ± .05	
			.XX ± .01	
			.XXX ± .005	
			FRACTIONS	
			± 1/64	
			ANGLES	
			± 0° 30'	
			CODE	
			ORIGINAL RELEASE	
			AP-112	
			SRG @ 1-7-65	
			DRAWN	
			CHECKED	
			TYPE & TEMPER	
			HEAT TREAT. SPEC.	
			MATERIAL	
			FINISH & SPEC. NO.	
			ENG. APP.	
			CHECKER	
			DRAFTS	
			CH. NO.	
			DATE	
			1.8.65	
			SCALE	
			UNLESS OTHERWISE SPECIFIED	
			DIMENSIONS ARE IN INCHES AND INCLUDE	
			CHEMICALLY APPLIED OR PLATED FINISHES	
			TOLERANCES	
			DECIMALS	
			.X ± .05	
			.XX ± .01	
			.XXX ± .005	
			FRACTIONS	
			± 1/64	
			ANGLES	
			± 0° 30'	
			CODE	
			ORIGINAL RELEASE	
			AP-112	
			SRG @ 1-7-65	
			DRAWN	
			CHECKED	
			TYPE & TEMPER	
			HEAT TREAT. SPEC.	
			MATERIAL	
			FINISH & SPEC. NO.	
			ENG. APP.	
			CHECKER	
			DRAFTS	
			CH. NO.	
			DATE	
			1.8.65	
			SCALE	
			UNLESS OTHERWISE SPECIFIED	
			DIMENSIONS ARE IN INCHES AND INCLUDE	
			CHEMICALLY APPLIED OR PLATED FINISHES	
			TOLERANCES	
			DECIMALS	
			.X ± .05	
			.XX ± .01	
			.XXX ± .005	
			FRACTIONS	
			± 1/64	
			ANGLES	
			± 0° 30'	
			CODE	
			ORIGINAL RELEASE	
			AP-112	
			SRG @ 1-7-65	
			DRAWN	
			CHECKED	
			TYPE & TEMPER	
			HEAT TREAT. SPEC.	
			MATERIAL	
			FINISH & SPEC. NO.	
			ENG. APP.	
			CHECKER	
			DRAFTS	
			CH. NO.	
			DATE	
			1.8.65	
			SCALE	
			UNLESS OTHERWISE SPECIFIED	
			DIMENSIONS ARE IN INCHES AND INCLUDE	
			CHEMICALLY APPLIED OR PLATED FINISHES	
			TOLERANCES	
			DECIMALS	
			.X ± .05	
			.XX ± .01	
			.XXX ± .005	
			FRACTIONS	
			± 1/64	
			ANGLES	
			± 0° 30'	
			CODE	
			ORIGINAL RELEASE	
			AP-112	
			SRG @ 1-7-65	
			DRAWN	
			CHECKED	
			TYPE & TEMPER	
			HEAT TREAT. SPEC.	
			MATERIAL	
			FINISH & SPEC. NO.	
			ENG. APP.	
			CHECKER	
			DRAFTS	
			CH. NO.	
			DATE	
			1.8.65	
			SCALE	
			UNLESS OTHERWISE SPECIFIED	
			DIMENSIONS ARE IN INCHES AND INCLUDE	
			CHEMICALLY APPLIED OR PLATED FINISHES	
			TOLERANCES	
			DECIMALS	
			.X ± .05	
			.XX ± .01	
			.XXX ± .005	
			FRACTIONS	
			± 1/64	
			ANGLES	
			± 0° 30'	
			CODE	
			ORIGINAL RELEASE	
			AP-112	
			SRG @ 1-7-65	
			DRAWN	
			CHECKED	
			TYPE & TEMPER	
			HEAT TREAT. SPEC.	
			MATERIAL	
			FINISH & SPEC. NO.	
			ENG. APP.	
			CHECKER	
			DRAFTS	
			CH. NO.	
			DATE	
			1.8.65	
			SCALE	
			UNLESS OTHERWISE SPECIFIED	
			DIMENSIONS ARE IN INCHES AND INCLUDE	
			CHEMICALLY APPLIED OR PLATED FINISHES	
			TOLERANCES	
			DECIMALS	
			.X ± .05	
			.XX ± .01	
			.XXX ± .005	