

REVISIONS						
ZONE	SYM	DESCRIPTION	DATE	E.M.N. NO.	DRAFT	CHKD
	X6	COMPLETELY REVISED & REDRAWN	8-26-66	-M-	Jc	
	X7	ON -G "C" WAS .187, ON DET "B", DIM "C" WAS DOUBLE FLAT	8-31-66	MM	Jc	JB
	X8	DELETED SECTIONAL ON DETAIL "E"; ADDED SECTIONAL TO DETAIL "D" ON CHART -3, 4 (F) WAS 2.125, ON PICT. "SET SCR ADJ." ADDED ON DETAIL "D" 3.71 DIM. WAS 3.718.	10/14/66	MM	Jc	JB
	X9	SEE SHEET 2 OF 2	10-11-66	MM	WHO	file
	Ø	ORIGINAL RELEASE FOR PRODUCTION	10/24/66	Ø	CV	

TMC PART NUMBER	MFG PT. NO.	DETAIL	A	B	C	D	E	F	G	H	I	J	K	* STOP	NO. OF TURNS FOR MIN CAPACITANCE STOP	N	LEAD SCREW THREADS	P O.D. OF TURNING HEAD	CAPACITANCE RANGE PF
CB172-1	CVCA1500-5N429	A	.250	.562	NONE	1.03	1/4	1 7/16	8-32NC2B, 6 HOLES ON 2.350 BC.	.41	4.41	2.650	3.38	L	---	NONE	LH	1.98	10 - 1500
CB172-2	CVCA2000-5N429	A	↑	↑	↑	1.03	1/4	1 7/16	8-32NC2B, 6 HOLES ON 2.350 BC.	.41	4.25	2.650	3.38	L	---	NONE	LH	↑	20 - 2000
CB172-3	CVDB1500-15N426	E				NONE	NONE	2 1/8	1/4-20 UNC 2B, 6 HOLES ON 4.750 BC.	.50	6.12	4.687	5.50	L	---	8-32NC-2B, 3 HOLES	RH		35 - 1500
CB172-4	CVDB2300-15N426	E			Y	NONE	NONE	2 1/8	1/4-20 UNC-2B, 6 HOLES ON 4.250 BC.	.50	6.12	4.687	5.50	L	---	8-32NC-2B, 3 HOLES	RH		50 - 2300
CB172-5	CVCA1500-5N502	A	Y	Y	NONE	1.03	1/4	1 7/16	8-32NC2B, 6 HOLES ON 2.350 BC.	.41	4.41	2.650	3.38	M	20/20.5 FROM MAX.	NONE	LH	Y	10 - 1500
CB172-6	CVCA2000-5N503	B	.250	.562	217/218	1.03	1/4	1 7/16	8-32NC2B, 6 HOLES ON 2.350 BC.	.41	4.25	2.650	3.38	M	20/20.5 FROM MAX.	NONE	LH	1.98	20 - 2000

* TYPE OF STOP: "L" - SET SCREW, MIN. CAPACITANCE STOP VARIABLE.
 "M" - SPACER, MIN. CAPACITANCE STOP FIXED.

NOTE: SEE CAPACITANCE VS TURNS GRAPH, SHEET 2.

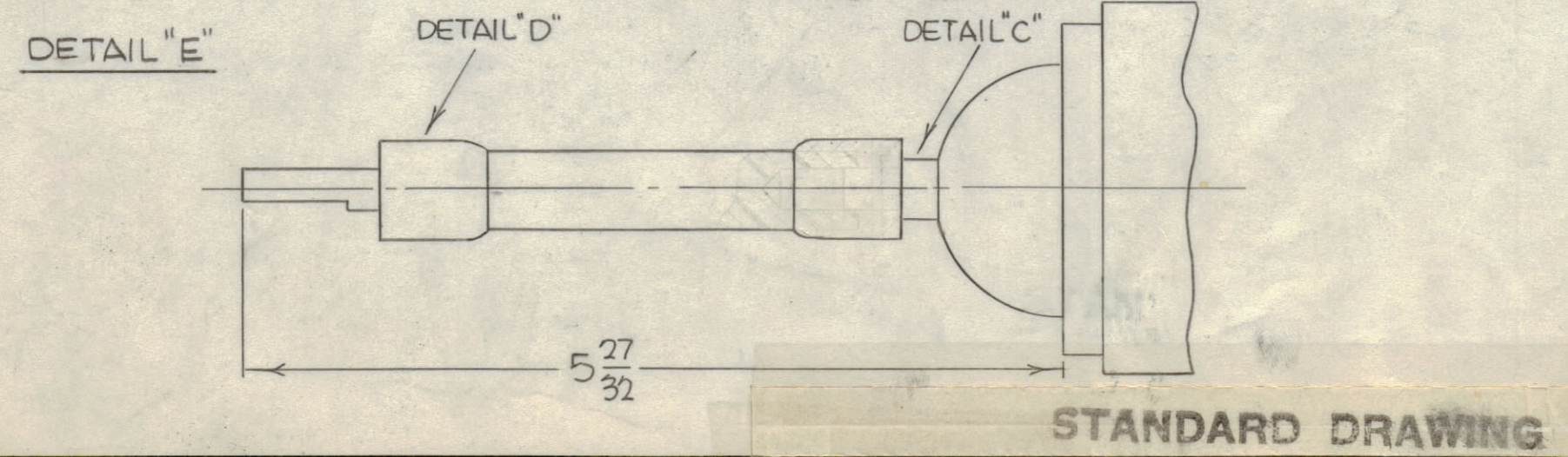
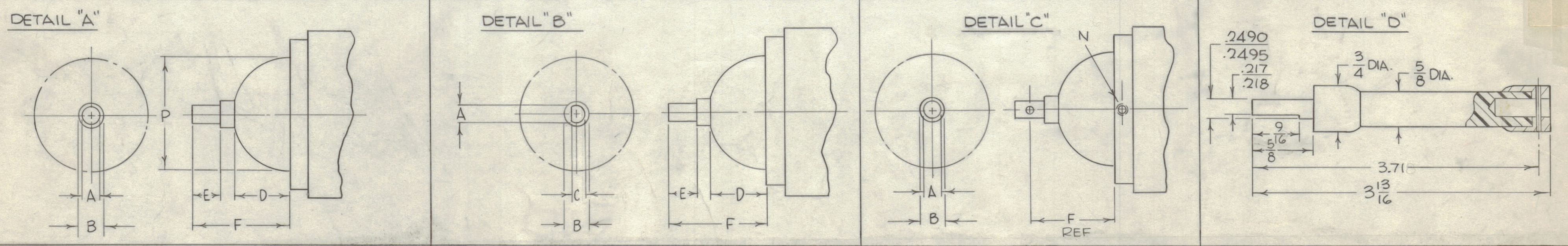

NOTE: SEE SHEET 2 OF 2 FOR SPECIFICATIONS

REQ'D.	ITEM	PART NUMBER	DESCRIPTION	SYMBOL
BUDETTI LIST OF MATERIAL				
MATERIAL			THE TECHNICAL MATERIEL CORP. MAMARONECK, NEW YORK	
FINISH			TITLE CAPACITOR, VARIABLE, CERAMIC, VACUUM	
Q'TY./UNIT		MODEL USED ON	ASS'Y. NO.	
SCALE		CODE	S401-48	
UNLESS OTHERWISE SPECIFIED DIMENSIONS ARE IN INCHES AND INCLUDE CHEMICALLY APPLIED OR PLATED FINISHES				
DECIMALS .X ± .05 .XX ± .01 .XXX ± .005		TOLERANCES ± 1/64 ANGLES ± 0° 30'		DRAWN G.S. DATE 5-1-65 CHECKED JHO DATE 10/17/66 ELECT. DES. DATE MECH. DES. DATE
THE CONTENTS OF THIS DRAWING ARE THE EXCLUSIVE PROPERTY OF THE TECHNICAL MATERIEL CORP. ITS UNAUTHORIZED USE OR REPRODUCTION IN WHOLE OR IN PART IS STRICTLY FORBIDDEN.			FINAL APPROVAL DATE 10/24/66 SHEET 1 OF 2	DATE REV. LTR.