

THE CONTENTS OF THIS DRAWING ARE THE EXCLUSIVE PROPERTY OF THE TECHNICAL MATERIEL CORP. ITS UNAUTHORIZED USE OR REPRODUCTION IN WHOLE OR IN PART IS STRICTLY FORBIDDEN.

REQ. PER UNIT
1

MODEL
CAB-4

USED ON
ASSY. NO.

DATE
1-15-62

CAB-4

SPECIFICATIONS

OVERALL DIM. - $20\frac{3}{8} \times 18 \times 6\frac{19}{32}$
 CABINET MATERIAL - Steel, Cold Rolled
 CABINET FINISH - Blue Gray Enamel
 PANEL MTG. - Universal Spacing
 PANEL SIZE - $19 \times 5\frac{1}{4}$
 MTG. DIM. - $14\frac{1}{2} \times 15\frac{1}{4}$

NOTICE TO PERSONS RECEIVING THIS DRAWING

THE TECHNICAL MATERIEL CORPORATION claims proprietary right in the material depicted herein. This drawing is issued in confidence for engineering information only and may not be reproduced or used to manufacture any machine shown here without permission from THE TECHNICAL MATERIEL CORPORATION to the user. This drawing is loaned for mutual assistance and is subject to recall at any time.

Property of:

THE TECHNICAL MATERIEL CORPORATION
 MAMARONECK, NEW YORK

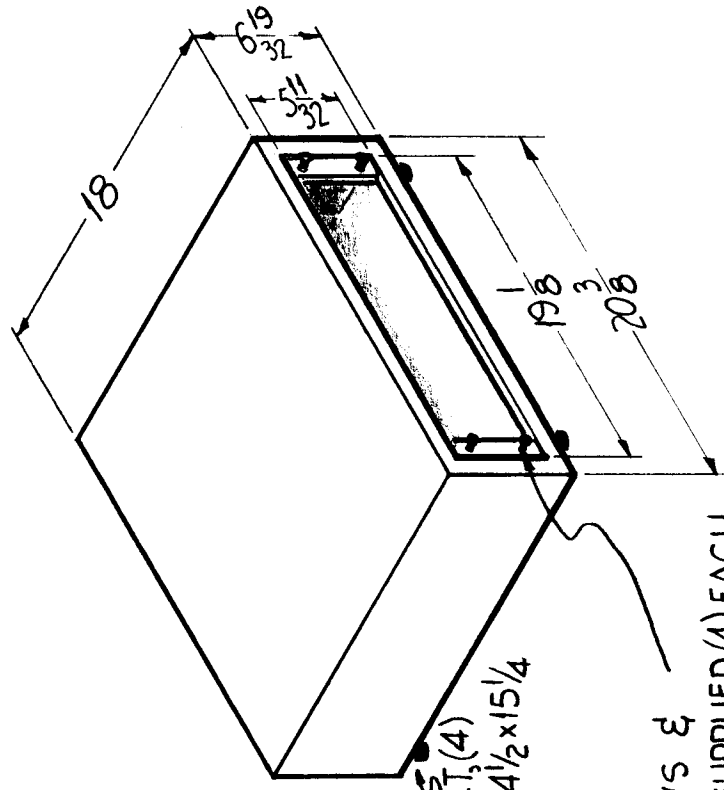

MOUNTING FEET, (4)
 SUPPLIED ON $14\frac{1}{2} \times 15\frac{1}{4}$
 CENTERS.

10-32 SCREWS &
 WASHERS SUPPLIED (4) EACH.

REQ. ITEM	PART NO.	DESCRIPTION	SYMBOL
		THE TECHNICAL MATERIEL CORP. MAMARONECK, NEW YORK	
		CABINET, ELECTRICAL, EQUIP.	
		MATERIAL	
		STOCK SIZE	
		TYPE & TEMPER	
		HEAT TREAT. SPEC.	
		DRAWN	
		CHECKED	
		FINAL APPROVAL	
		FINISH & SPEC. NO.	
		ELEC. DES. APP. MECH. DES. APP.	

UNLESS OTHERWISE SPECIFIED:

DIMENSIONS ARE IN INCHES
 TOLERANCES ON
 FRAC. $\pm .004$ DEC. $\pm .008$ ANGLES $\pm 1/2^\circ$

SCALE: A-2287
 MAXIMUM ALLOWABLE TOLERANCES HAVE BEEN DETERMINED AND ANY DEVIATIONS WILL BE CAUSE FOR REJECTION.
 REMOVE ALL BURRS AND SHARP EDGES