

REVISIONS						
SYM	DESCRIPTION	DATE	E.M.N. NO.	DRAFT	CHKD	APPD
Ø	ORIGINAL RELEASE FOR PRODUCTION	9/25/69		W		

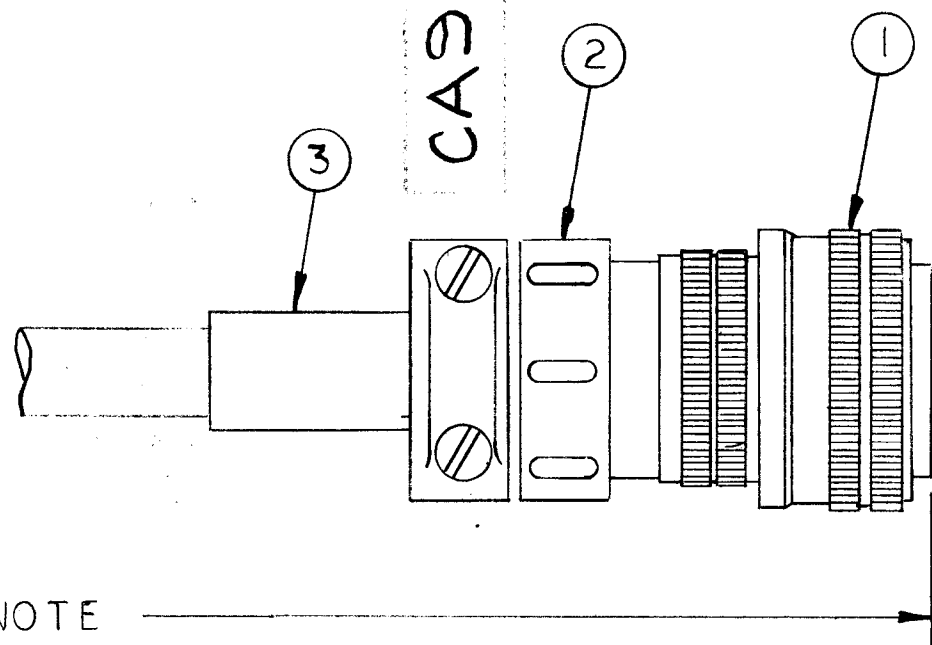
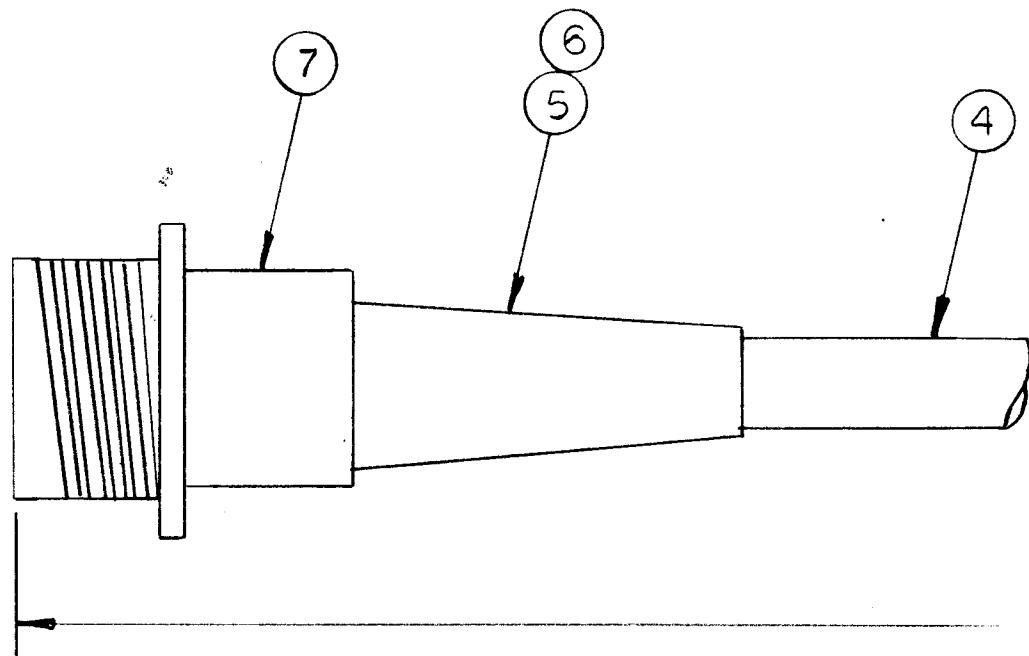

CA978

SEE NOTE

NOMENCLATURE TO BE AS FOLLOWS:

CA-978 - XXX

TMC DWG. NO. ——— LENGTH (INCHES)

NOTE:  
ITEM 4 LENGTH DEPENDS ON CA-978 LENGTH.

ITEM 4 WIRE COLOR	TO ITEM 1 PIN #	TO ITEM 7 PIN #
BLACK	A	A
WHITE	B	B
RED	C	C
GREEN	D	D
YELLOW	E	E
BLUE	F	F
BROWN	G	G
ORANGE	H	H
VIOLET	J	J
GRAY	K	K

NOTES

1	RAK-106	A-1739
Q'TY./UNIT	MODEL USED ON	ASS'Y. NO.
SCALE	CODE	

THE CONTENTS OF THIS DRAWING ARE THE EXCLUSIVE PROPERTY OF THE TECHNICAL MATERIEL CORP. ITS UNAUTHORIZED USE OR REPRODUCTION IN WHOLE OR IN PART IS STRICTLY FORBIDDEN.

REQ'D.	ITEM	PART NUMBER	DESCRIPTION	SYMBOL
	8	BS-100	SOLDER, SOFT	
1	7	MS3102A20-27S	CONNECTOR, RECEPTACLE, FEMALE	
	6	CD1014WM	CORD, LACING	
	5	TA-100-1	TAPE, ELEC.	
	4	WI-112-7	CABLE, MULTI-COND. (10)	
1	3	MS3420-10A	BUSHING, RUBBER	
1	2	MS3057-12	CLAMP, CABLE	
1	1	MS3106A20-27P	CONNECTOR, PLUG, MALE	

LIST OF MATERIAL

MATERIAL		THE TECHNICAL MATERIEL CORP. MAMARONECK, NEW YORK			
FINISH		TITLE CABLE ASSEMBLY SPECIAL, PURPOSE			
UNLESS OTHERWISE SPECIFIED DIMENSIONS ARE IN INCHES AND INCLUDE CHEMICALLY APPLIED OR PLATED FINISHES		DRAWN	DATE	FINAL APPROVAL	DATE
DECIMALS .X ± .05 .XX ± .01 .XXX ± .005		CHECKED	DATE	S/M	9/25/69
FRACTIONS ± 1/64 ANGLES ± 0° 30'		ELECT. DES.	DATE		
TOLERANCES		MECH. DES.	DATE	CA-978	Ø
		SHEET	REV. LTR.		