

| TMC PART NO | STYLE | A-A | ITEM 1 | ITEM 3 | QTY | ITEM 4 | QTY | ITEM 2 | GROUND COLOR |
|-------------|-------|-------|--------|-------------|-----|---------|-----|----------|--------------|
| CA751-1 | A | 1 1/2 | PL218 | TE120-2 | 3 | # | # | WI121-9 | GREEN |
| CA751-2 | B | 1 | PL218 | # | # | TE120-2 | 1 | WI121-9 | GREEN |
| CA751-3 | A | 3 | PL176 | TE156-34149 | 3 | # | # | WI121-9 | GREEN |
| CA751-4 | A | 1-1/2 | PL218 | # | # | # | # | WI112-2 | RED |
| CA751-5 | C | 2-1/2 | PL218 | | | | | WI124-10 | GREEN |

| REVISIONS | | | | | | | |
|-----------|-----|---|---------|----------|-------|------|------|
| ZONE | LTR | DESCRIPTION | DATE | E.M.N.NO | DRAFT | CHKD | APPD |
| | A | COMPLETELY REVISED & REDRAWN | 4-21-67 | 18091 | | | |
| | B | OLD PT/N. CHT-3 DEL. STYLE "C" DEL. | 6-20-67 | 18275 | WHD | | RH |
| | C | P/N. & REF. NO'S UPDATED | 10.5.67 | 18540 | H.G. | | EFM |
| | D | ADDED CA751-4 CHARTS ITEM 2 & GROUND COLOR, ON ITEM 2 "SEE CHART WAS WI121-9" | 1-16-68 | 19200 | GE | | FB |
| | E | DASH 5 ADDED | 5-21-69 | 19447 | GE | | BP |
| | F | ADD STYLE C | 8-18-70 | 19960 | GE | | W. |

| | | |
|-----------------------|-------------|------------|
| CA751-1 CA751-A-75 | REPLACED BY | CA751-1-75 |
| CA751-2 CA751-B-72 | REPLACED BY | CA751-2-72 |
| CA751-3 CA751-A-30 | REPLACED BY | CA751-3-30 |

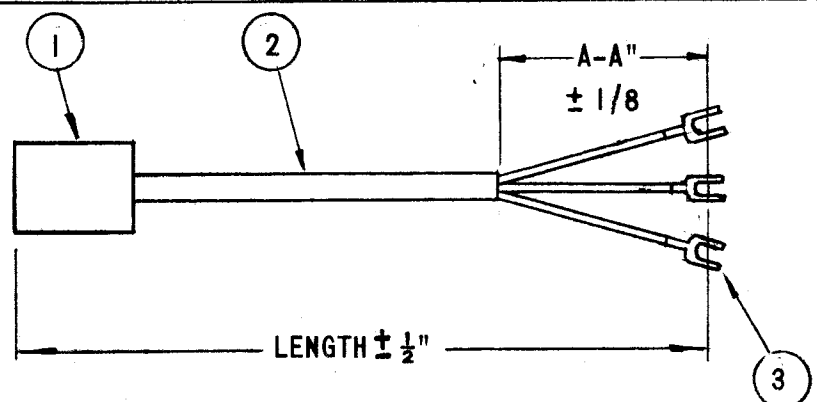

STYLE A

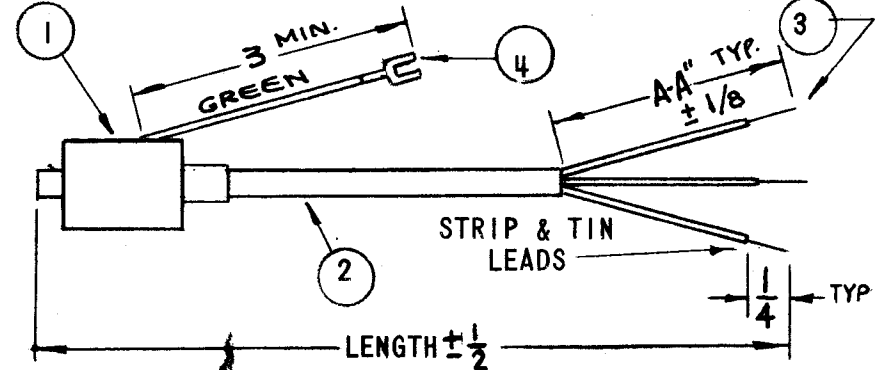

NOTE: PL218 (ITEM 1) WITH GROUND STRAP REMOVED

STYLE B

CA751-144

TMC BASIC P/N

LENGTH EXP IN INCHES (EX. 144 = 12'-0")

| REQ'D | ITEM | PART NUMBER | DESCRIPTION | SYM. |
|-------|------|-------------|---------------------------|------|
| X | 5 | BS100 | SOLDER, TIN ALLOY | |
| X | 4 | SEE CHART | TERM, LUG SPADE | |
| X | 3 | SEE CHART | TERM, LUG SPADE | |
| X | 2 | SEE CHART | CABLE 3 WIRE | |
| I | 1 | SEE CHART | CABLE POWER, 3 CONDUCTORS | |

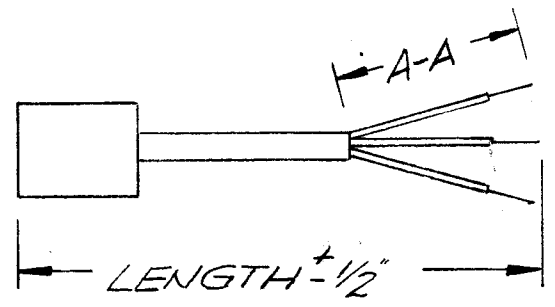

STYLE C

| QTY / UNIT | MODEL USED ON | ASS'Y NO. |
|-------------|---------------|-----------|
| 1 | PMO-4,5,6 | |
| APPLICATION | | |
| S401-451 | CODE A | |

NOTICE TO PERSONS RECEIVING THIS DRAWING
 THE TECHNICAL MATERIEL CORPORATION claims proprietary right in the material disclosed hereon. This drawing is issued in confidence for engineering information only and may not be reproduced or used to manufacture anything shown hereon without permission from THE TECHNICAL MATERIEL CORPORATION to the user. This drawing is loaned for mutual assistance and is subject to recall at any time.

| STANDARD | | PRITCHARD | |
|---|--------------|-------------|---------|
| UNLESS OTHERWISE SPECIFIED DIMENSIONS ARE IN INCHES AND INCLUDE CHEMICALLY APPLIED OR PLATED FINISHES | | | |
| DECIMALS | FRACTIONS | ELECT. DES. | DATE |
| .X ± .05 | 1/64 | | 7/25/67 |
| .XX ± .01 | TOLS. ANGLES | CHECKED | DATE |
| .XXX ± .005 | 0° .30' | JAW | 7/25/67 |
| MATERIAL | | DRAWN | DATE |
| | | | 4-21-67 |
| FINISH | | | |

| LIST OF MATERIAL | | | |
|------------------------------|-----------------|---------|-------|
| THE TECHNICAL MATERIEL CORP. | | | |
| MAMARONECK, NEW YORK | | | |
| CABLE ASS'Y POWER | | | |
| NON RETRACTABLE | | | |
| SIZE | CODE IDENT. NO. | DWG NO. | ISSUE |
| B | 82679 | CA751 | F |
| SCALE | SHEET | | OF |