

BX-165

TMC TYPE TE-101-2
COMPLETE WITH SOLDER LUG & NUT
4 REQ.

6-32 X 1/4 STUDS-SINGLE END - 4 REQ.

METAL STAMP AS SHOWN
1-2-3-4-500-50-G & TR-034

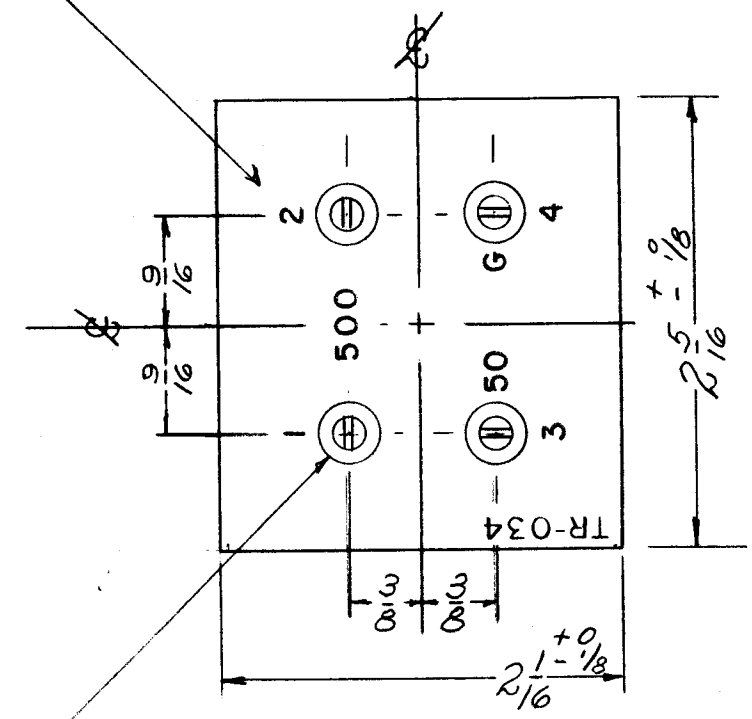

HOLE $\frac{7}{32}$ (.218) DIA - 4 REQ.
POSITION LUGS EXACTLY AS SHOWN

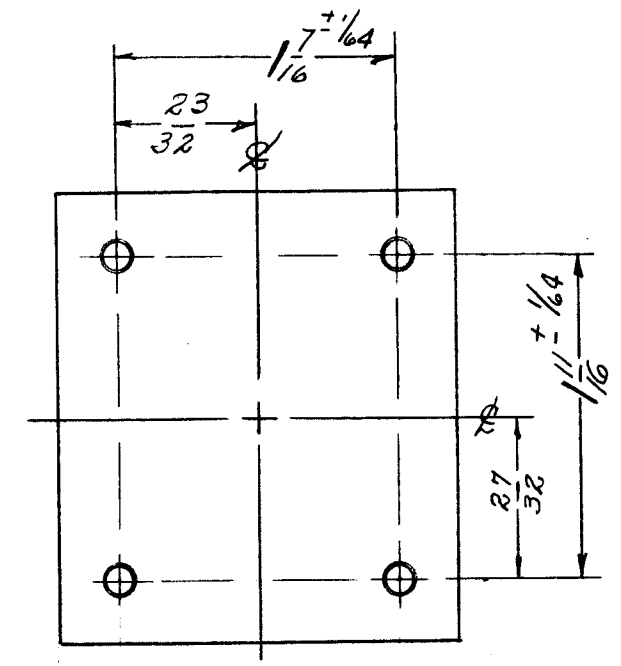
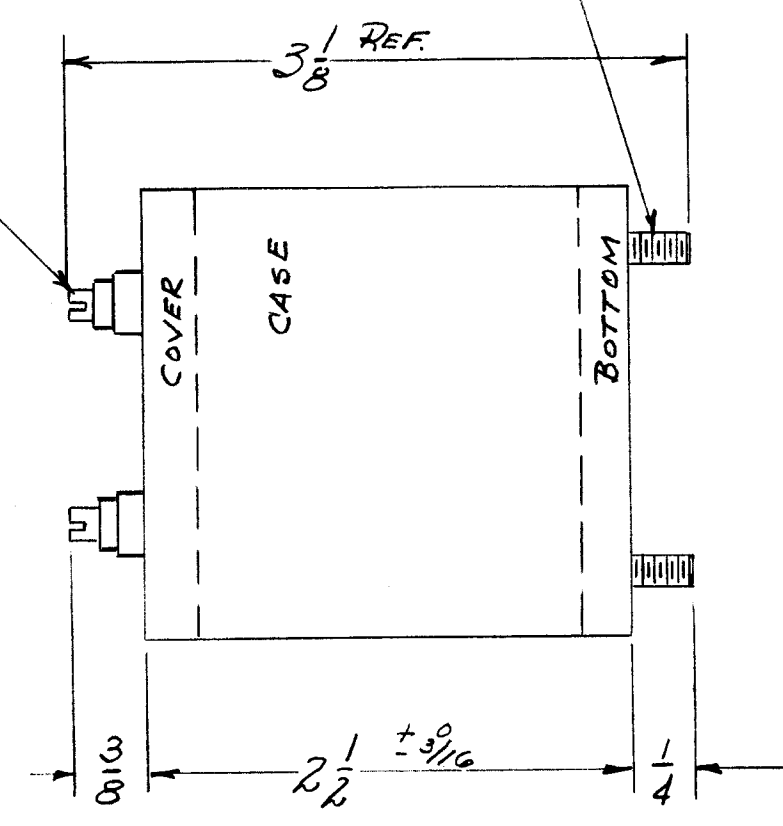

NOTICE TO PERSONS RECEIVING THIS DRAWING

THE TECHNICAL MATERIEL CORPORATION claims proprietary right in the material disclosed hereon. This drawing is issued in confidence for engineering information only and may not be reproduced or used to manufacture anything shown hereon without permission from THE TECHNICAL MATERIEL CORPORATION to the user. This drawing is loaned for mutual assistance and is subject to recall at any time.

Property of:
THE TECHNICAL MATERIEL CORPORATION
MAMARONECK, NEW YORK

REF. HELDOR MFG. Co. CAT. No. 108-FB MODIFIED

ISSUE	ITEM	CHANGED FROM	DATE	CH. NO.	DRAFTS	CHECKER	ENG. APP.
TOLERANCES			SCALE: <i>1:1</i>				
DEC. DIM. ±			MAXIMUM ALLOWABLE TOLERANCES HAVE BEEN DETERMINED AND ANY DEVIATIONS WILL BE CAUSE FOR REJECTION. REMOVE ALL BURRS AND SHARP EDGES				
FRAC. DIM. ±							
ANGULAR DIM. ±							

1	RAC-9	A-1565	8-5-58
REQ. PER UNIT	MODEL	PROJECT NO.	ASS'Y. NO.
USED ON			

REQ. ITEM	PART NO.	DESCRIPTION	SYMBOL
	.019 - .025 THICK STOCK SIZE	THE TECHNICAL MATERIEL CORP. MAMARONECK, NEW YORK	
	STEEL	CASE, TRANSFORMER	
		MATERIAL	
		TYPE & TEMPER	HEAT TREAT. SPEC.
		FINISH & SPEC. NO.	
		DRAWN	CHECKED
		ELEC. DES. APP.	MECH. DES. APP.

BX-165