

BX-144 B

NOTE POSITION OF TERMINALS

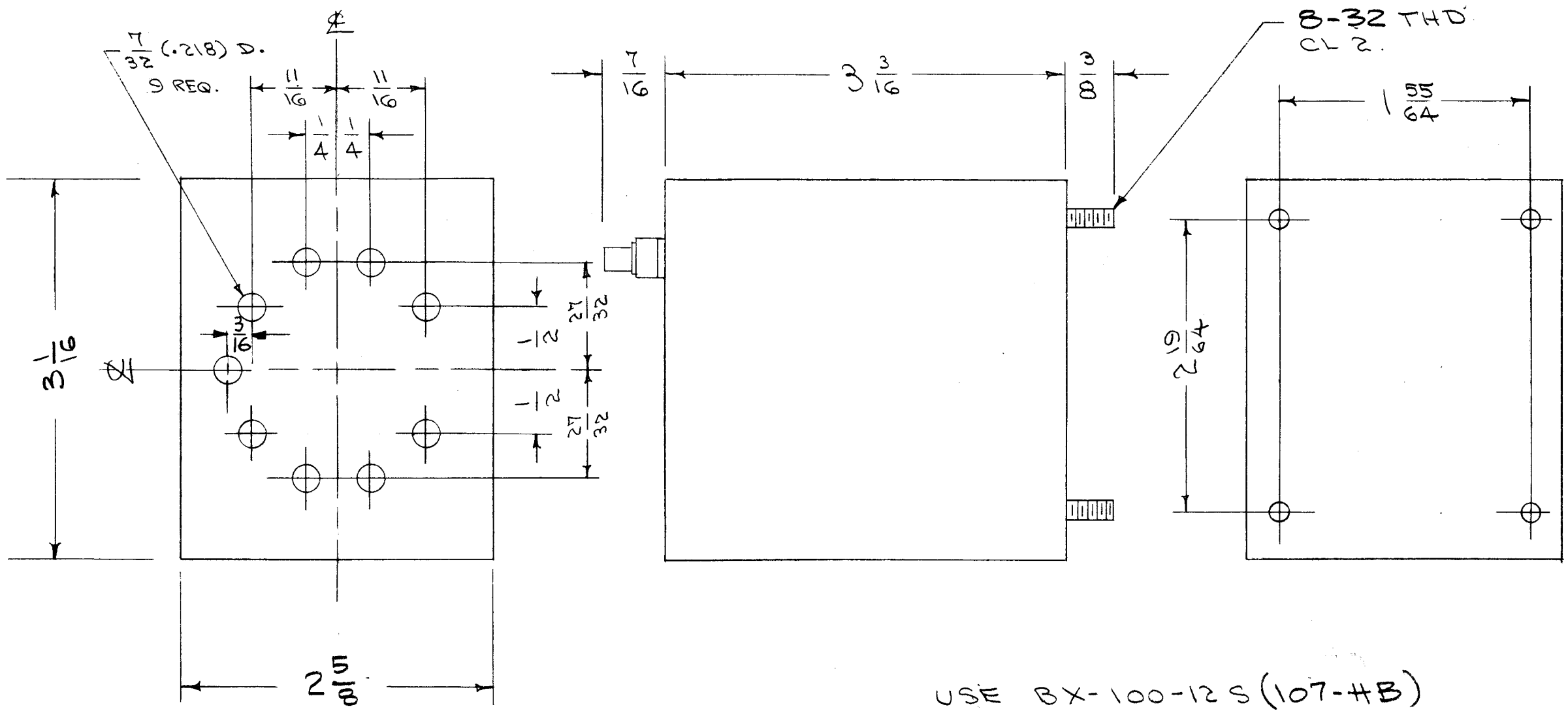
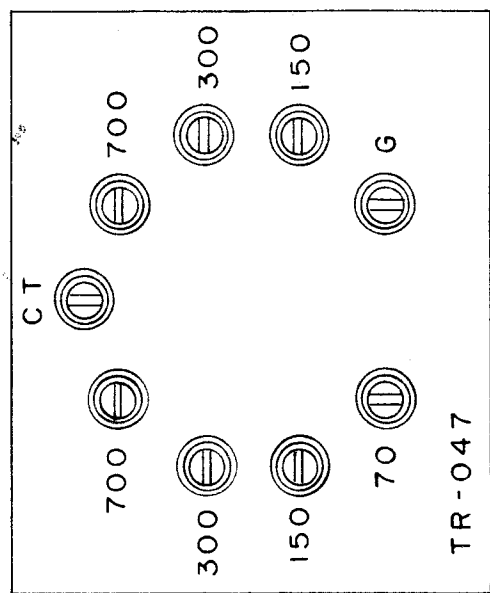

1/8 HIGH METAL STAMP AS ABOVE

USE BX-100-12 S (107-#B) MODIFY AS SHOWN.

TERMINALS -  
TMC NO. - TE-101-2  
HELDOR NO - 312-A

NOTICE TO PERSONS RECEIVING THIS DRAWING

THE TECHNICAL MATERIEL CORPORATION claims proprietary right in the material disclosed herein. This drawing is issued in confidence for engineering information only and may not be reproduced or used to manufacture anything shown hereon without permission from THE TECHNICAL MATERIEL CORPORATION to the user. This drawing is loaned for mutual assistance and is subject to recall at any time.

Property of:

THE TECHNICAL MATERIEL CORPORATION  
MAMARONECK, NEW YORK

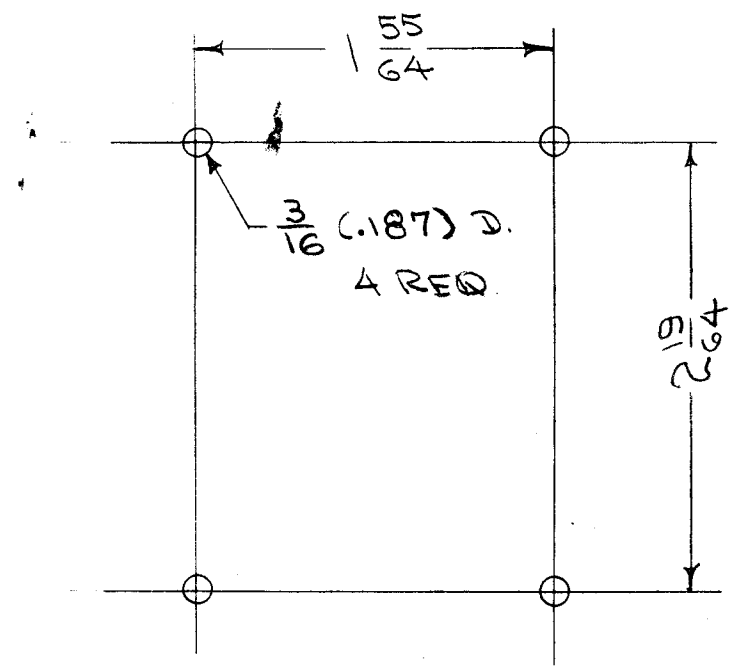

REF: HELDOR MFG. CO.

ISSUE	ITEM	CHANGED FROM	DATE	CH. NO.	DRAFTS	CHECKER	ENG. APP.
B	1	3/16 DIM ADDED	2/14/61	4146	JDM	JCS	SPM
A	1	O/A DIM. CHGD. FROM 2.555 X 3 TO 2-5/8 X 3-1/16 ACC TO MIL-T-27A - 8-32 THD. WAS 6-32	1/6/58	1	16	JMO	JCS
TOLERANCES			SCALE:				
DEC. DIM. ±			MAXIMUM ALLOWABLE TOLERANCES HAVE BEEN DETERMINED AND ANY DEVIATIONS WILL BE CAUSE FOR REJECTION.				
FRAC. DIM. ± 1/64			REMOVE ALL BURRS AND SHARP EDGES				
ANGULAR DIM. ±							

1	TRC-100	480	A-1290	5-9-56
REQ. PER UNIT	MODEL	PROJECT NO.	ASS'Y. NO.	DATE
USED ON				

REQ. ITEM	PART NO.	DESCRIPTION	SYMBOL
THE TECHNICAL MATERIEL CORP. MAMARONECK, NEW YORK			
STOCK SIZE			
TRANSFORMER CAN			
MATERIAL			
TR-047			
TYPE & TEMPER		HEAT TREAT. SPEC.	SYMBOL
DRAWN		CHECKED	FINAL APPROVAL
FINISH & SPEC. NO.		ELEC. DES. APP.	MECH. DES. APP.