

IF IT IS FOUND DESIRABLE TO CHANGE ANY TOLERANCE OR OTHER DETAIL SPECIFIED ON THIS DRAWING NOTIFY THE PURCHASER PROMPTLY.

MAXIMUM ALLOWABLE TOLERANCES HAVE BEEN DETERMINED AND DEVIATIONS WILL BE CAUSE FOR REJECTION. REMOVE ALL BURRS AND SHARP EDGES

BX-137 C

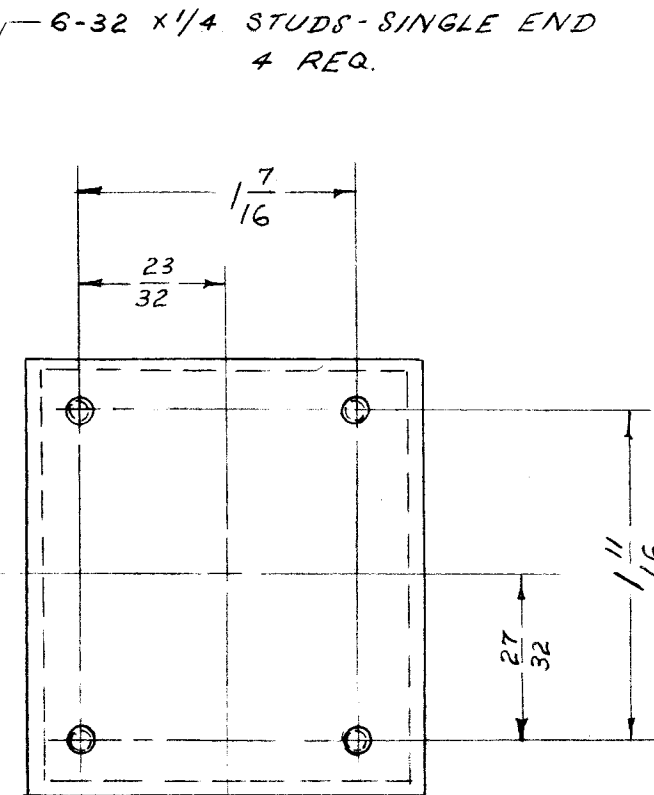
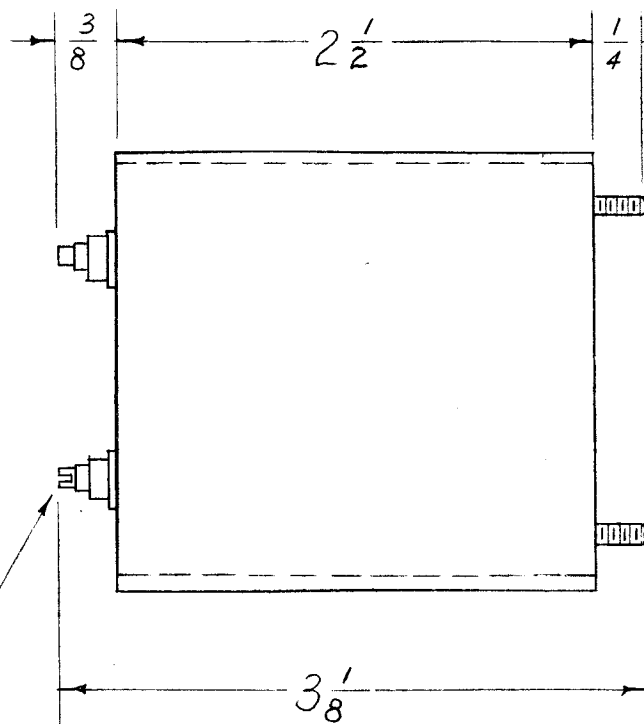
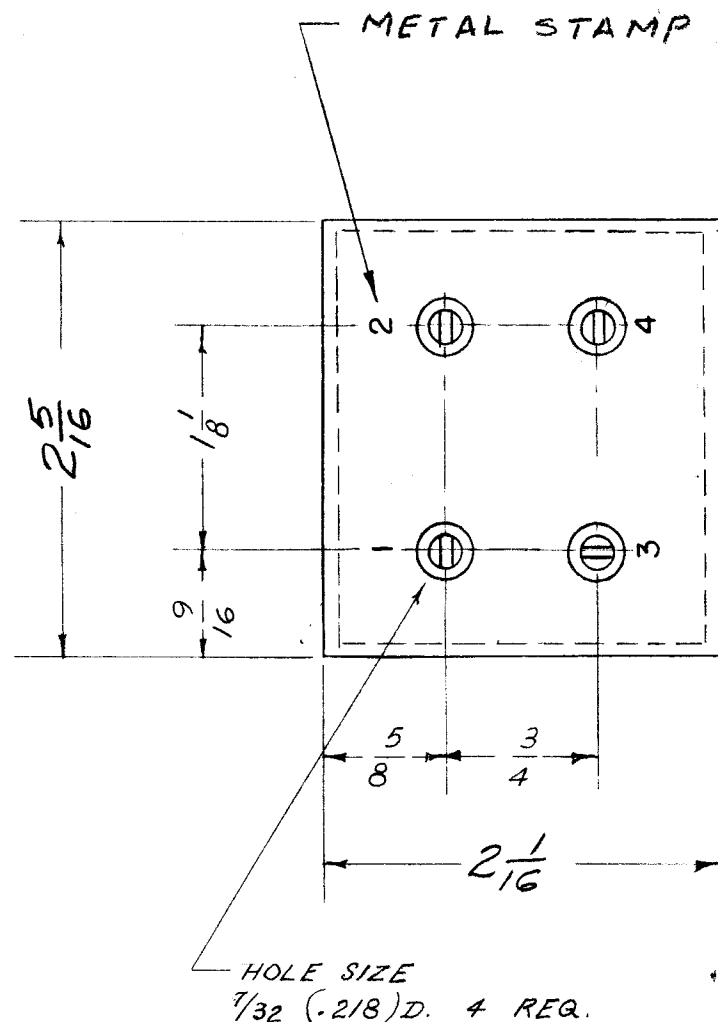

DIMENSIONS FOR REF. ONLY

NOTICE TO PERSONS RECEIVING THIS DRAWING

THE TECHNICAL MATERIEL CORPORATION claims proprietary right in the material disclosed hereon. This drawing is issued in confidence for engineering information only and may not be reproduced or used to manufacture anything shown hereon without permission from THE TECHNICAL MATERIEL CORPORATION to the user. This drawing is loaned for mutual assistance and is subject to recall at any time.

Property of:

THE TECHNICAL MATERIEL CORPORATION
MAMARONECK, NEW YORK

REF: TMC #100-8D (HELDOR MFG. 108-FB MODIFIED)

ISSUE	ITEM	CHANGED FROM	DATE	CN. NO.	DRAFTS	CHECKER	ENG. APP.
C	1	O/A DIM. CHGD. FROM 2.012 X 2.240 TO 2-1/16 X 2-5/16 ACC. TO MIL-T-27A	1/6/58	3	16	JAG	AK
B	1	FINISH WAS ELECTRO TIN	8/3/55	2	2	JAG	AK
A	1	REF: WAS BX-100-85	5/20/55	1	1	JAG	AK

TOLERANCES		SCALE:
ALL OTHERS	DEC. DIM. ± FRAC. DIM. ± ANGULAR DIM. ±	DRILL, PUNCH, COMMERCIAL STOCK SIZES AND MANUFACTURERS TOLERANCES ARE NOT INCLUDED.

REQ. PER UNIT	MODEL	PROJECT NO.	ASS'Y. NO.	DATE
1	TR-112		A-988	4-7-55
USED ON				

REQ.	ITEM	PART NO.	DESCRIPTION	SYMBOL
		.019 - .025	THE TECHNICAL MATERIEL CORP.	
		STOCK SIZE	MAMARONECK, NEW YORK	
		STEEL	CASE TRANSFORMER	
		MATERIAL	TR-112	
		WEIGHT PER PC.	P.B. 4-7-55	
		TYPE & TEMPER	DRWN	ELEC. DES. APP.
			JAG	ARB
		HEAT TREAT. SPEC.	CHECKED	FINAL APPROVAL
		HOT-TINNED		
		FINISH & SPEC. NO.		

BX-137 C