

STAMP TMC PART NO.  
1/8 HIGH BLACK GOTHIC  
WITH LATEST REV. LETTER

REVISIONS					
SYM	DESCRIPTION	DATE	E.M.N. NO.	DRAFT	CHKD APPD
Ø	ORIGINAL RELEASE FOR PRODUCTION	10-29-64	Ø	PL	
A	ON SPECS., #2: VOLT. WAS 24; #3: NOM. CAP. WAS NOM. V. CAP. ON S401 # (215103) WAS (37261).	4-2-65	13833	PL	<i>[Signature]</i>

BA-101

**SPECIFICATIONS**

1. TYPE: NICKEL-CADMIUM, RECHARGEABLE
2. VOLTAGE: 26.5 VOLTS
3. NOM. CAPACITY: 2.5 AMP-HR. @ 5 HR RATE
4. TERMINAL: WIRE LEADS
5. MATERIAL: CASE - STAINLESS STEEL, 1/32 THICK  
COVER - STAINLESS STEEL, 1/32 THICK  
MOUNTING BRACKETS - STAINLESS STEEL, 1/16 THICK
6. VENTED CELLS
7. NON-SPILLABLE
8. CHARGE RATE: 400 MA FOR 14 HOURS

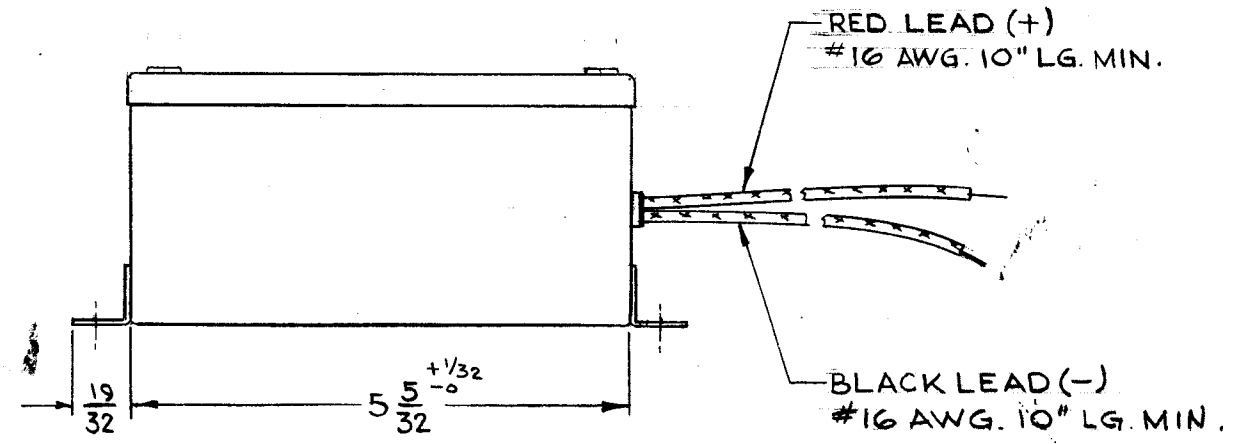

REQ'D.	ITEM	PART NUMBER	DESCRIPTION	SYMBOL
POSE LIST OF MATERIAL				
MATERIAL			THE TECHNICAL MATERIEL CORP. MAMARONECK, NEW YORK	
FINISH			TITLE BATTERY, STORAGE	
UNLESS OTHERWISE SPECIFIED DIMENSIONS ARE IN INCHES AND INCLUDE CHEMICALLY APPLIED OR PLATED FINISHES			DRAWN TRAMIREZ	DATE 2-12-64
DECIMALS .X ± .05 .XX ± .01 .XXX ± .005			CHECKED @	DATE 11-19-64
FRACTIONS ± 1/64 ANGLES ± 0° 30'			ELECT. DES. <i>[Signature]</i>	DATE 10/19/64
TOLERANCES			MECH. DES. <i>[Signature]</i>	DATE 10-29-64
THE CONTENTS OF THIS DRAWING ARE THE EXCLUSIVE PROPERTY OF THE TECHNICAL MATERIEL CORP. ITS UNAUTHORIZED USE OR REPRODUCTION IN WHOLE OR IN PART IS STRICTLY FORBIDDEN.			APPROVAL <i>[Signature]</i> BA-101	
NOTES			SHEET	
			REV. LTR.	