

REVISIONS						
ZONE	LTR	DESCRIPTION	DATE	E.M.N.NO	DRAFT	CHKD APPD
	XI	ADDED IT. 1	5/26/69	#	GE	
	Ø	ORIGINAL RELEASE FOR PRODUCTION	5/26/69	#	GE	

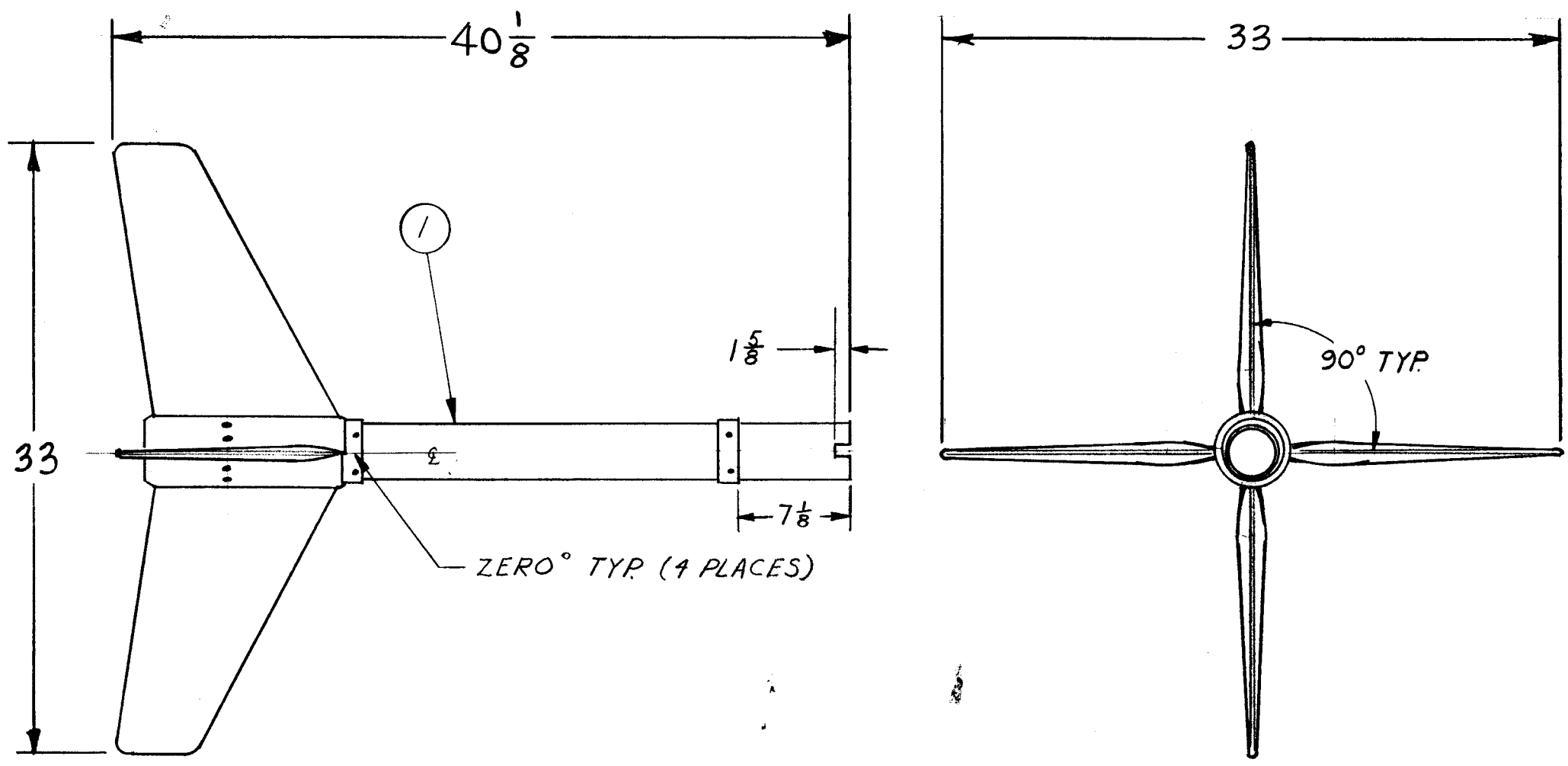

REQ'D	ITEM	PART NUMBER	DESCRIPTION	SYM.
1	1	MS 8304	SHAFT SUB-ASSY	

LIST OF MATERIAL

QTY / UNIT	MODEL USED ON	ASS'Y NO.
1	ATW-1	ID8054
APPLICATION		
	CODE	

**NOTICE TO PERSONS RECEIVING THIS DRAWING**  
 THE TECHNICAL MATERIEL CORPORATION claims proprietary right in the material disclosed hereon. This drawing is issued in confidence for engineering information only and may not be reproduced or used to manufacture anything shown hereon without permission from THE TECHNICAL MATERIEL CORPORATION to the user. This drawing is loaned for mutual assistance and is subject to recall at any time.

UNLESS OTHERWISE SPECIFIED DIMENSIONS ARE IN INCHES AND INCLUDE CHEMICALLY APPLIED OR PLATED FINISHES

DECIMALS: .X ± .05, .XX ± .01, .XXX ± .005  
 FRACTIONS: 1/64, ANGLES: 0°-30'

FINISH: REF AX 8083

FINAL APPROVAL: *SPM* DATE: 5/19/69  
 MECH. DES. DATE:  
 ELECT. DES. DATE:  
 CHECKED: *DMG* DATE: 5-9-69  
 DRAWN: TANTILLO DATE: 7-11-68

THE TECHNICAL MATERIEL CORP.  
 MAMARONECK, NEW YORK

TAIL FIN SUB-ASSEMBLY

SIZE	CODE IDENT. NO.	DWG NO.	ISSUE
B	82679	AX8084	Ø

SCALE 1/8" = 1" SHEET OF