

APPLICATION			REVISIONS						
QTY	MODEL USED ON	ASS'Y NO.	LTR	DESCRIPTION	DATE	E.M.N.NO	DRAFT	CHKD	APPD
1	GPT-10K		Ø	Original Release for Production	9-14-82	~			

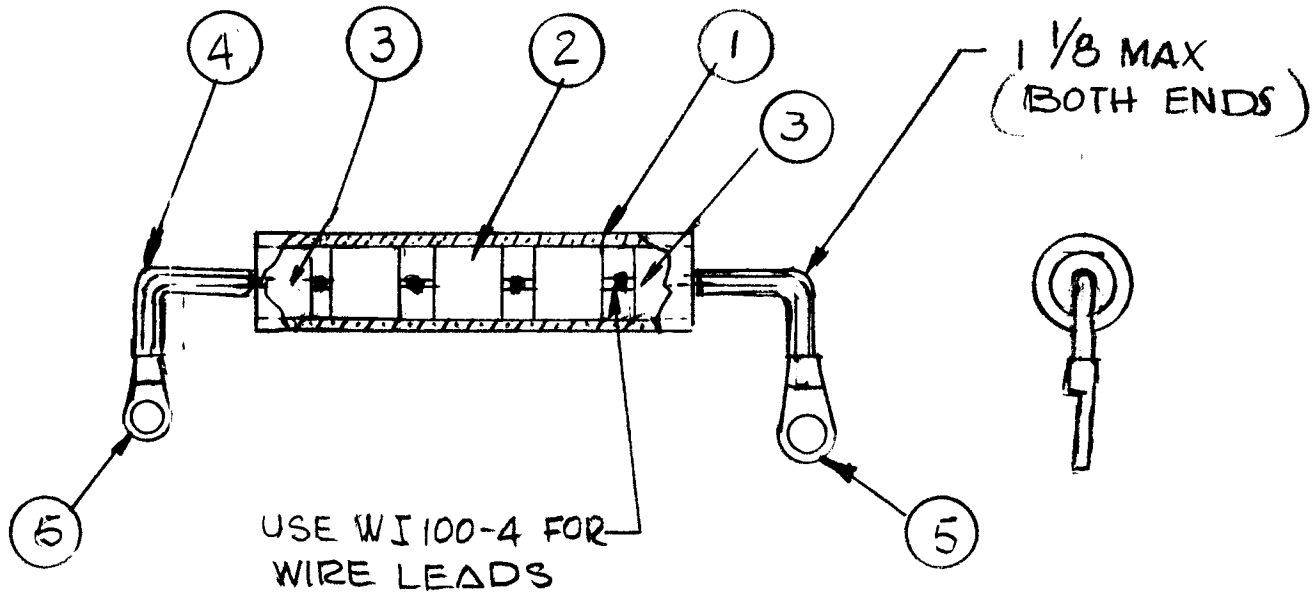

X	7	BS 100	SOLDER	
X	6	BST00	SOLDER, TIN ALLOY	
2	5	TE165 FOR STD 6-32	LUG	
1	4	PX370-	INS. TEFLON	
2	3	PX1288	INSERT	
3	2	CC109-5	CAPACITOR	
1	1	PX1292	CAPACITOR, COVER	

UNLESS OTHERWISE SPECIFIED DIMENSIONS ARE IN INCHES AND INCLUDE CHEMICALLY APPLIED OR PLATED FINISHES		REQ'D	ITEM	PART NUMBER	DESCRIPTION	SYM.
DECIMALS X ± .05 .XX ± .01 .XXX ± .005		FRACTIONS 1/64 ANGLES 0°-30°		LIST OF MATERIAL THE TECHNICAL MATERIEL CORP. MAMARONECK, NEW YORK ASSY CAP H.V (3 pf)		
MATERIAL FINISH		FINAL APPROVAL <i>JR</i>		DATE 4/19/82		
		MECH. DES.		DATE		
		ELECT. DES.		DATE		
		CHECKED		DATE		
		DRAWN <i>GDL</i>		DATE		

NOTICE TO PERSONS RECEIVING THIS DRAWING THE TECHNICAL MATERIEL CORPORATION claims proprietary right in the material disclosed hereon. This drawing is issued in confidence for engineering information only and may not be reproduced or used to manufacture anything shown hereon without permission from THE TECHNICAL MATERIEL CORPORATION to the user. This drawing is loaned for mutual assistance and is subject to recall at any time.				SIZE A	CODE IDENT. NO. 82679	DWG NO. AX 807	ISSUE Ø
SCALE 1:1			SHEET OF				