

REVISIONS						
ZONE	LTR	DESCRIPTION	DATE	E.M.N.NO	DRAFT	CHKD APPD
	X	EXP. RELEASE	4-11-67			
	Ø	ORIG RELEASE FOR PROD.	4-14-67		RG	

TOP VIEW

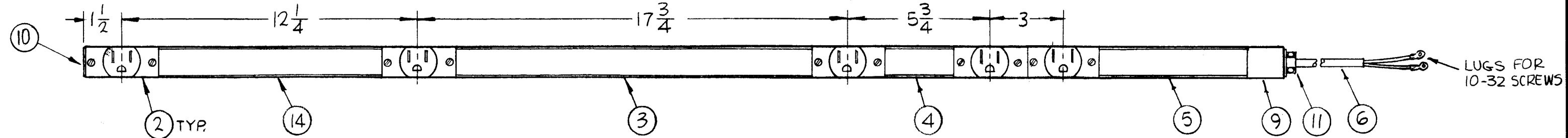

49 1/2 APPROX.

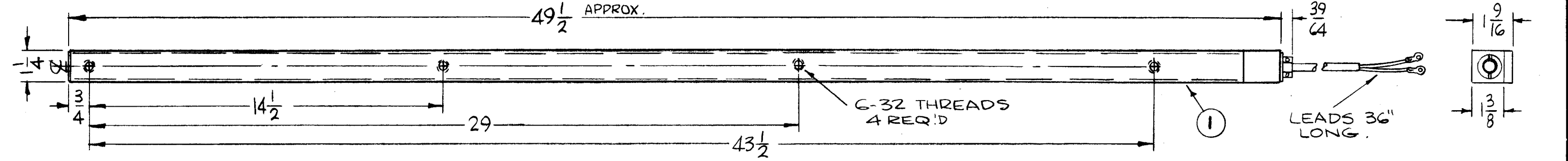

BOTTOM VIEW

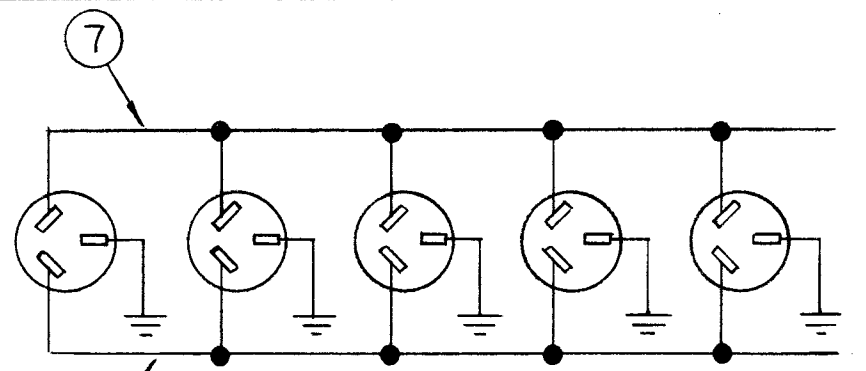

SCHEMATIC DIAGRAM

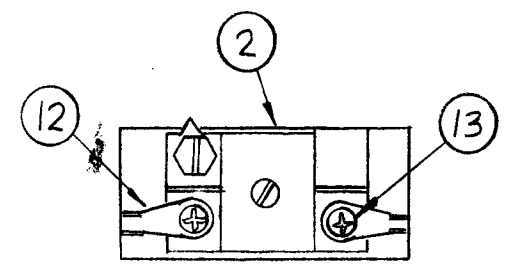

CONNECTOR DETAIL

REPLACES DISCARDED SCREWS.

REQ'D	ITEM	PART NUMBER	DESCRIPTION	SYM.
X	15	BS100	SOLDER, TIN ALLOY	
1	14	PO163-9.250	COVER, CND	
10	13	SCBP0832BN4	SCREW, MACHINE	
10	12	TE112-3	TERM, LUG LKG	
1	11	CU113	BOX, CONN ELEC	
1	10	PO161	END FTG, BLANK	
1	9	PO162	CONDUIT OUTLET	
X	8	MWC14(19)U0	WIRE, ELEC INS	BLK
X	7	MWC14(19)U9	WIRE, ELEC INS	WHT
1	6	CA588-1	CBL ASSY, PWR, AC	
1	5	PO163-6.250	COVER, CND	
1	4	PO163-2.750	COVER, CND	
1	3	PO163-14.750	COVER, CND	
5	2	JJ337	CONN, RECP ELEC	
1	1	MS2306	CND, AC STRIP	

THE TECHNICAL MATERIEL CORP.
MAMARONECK, NEW YORK

AC POWER STRIP ASS'Y

NOTE:
THIS DRAWING REPLACES
AX 247 (A2051)

QTY / UNIT	MODEL USED ON	ASS'Y NO.
	RAK-19D	
	RAK-19C	
	RAK-19B	
	RAK-19A	
APPLICATION		
S401-451	CODE A	

UNLESS OTHERWISE SPECIFIED
DIMENSIONS ARE IN INCHES
AND INCLUDE CHEMICALLY APPLIED
OR PLATED FINISHES

DECIMALS .X ± .05 FRACTIONS 1/64
.XX ± .01 TOLS. ANGLES
.XXX ± .005 0° .30'

MATERIAL

FINISH
S115 GREY ENAMEL

FIN. DES. <i>[Signature]</i>	DATE <i>[Date]</i>
CHECKED <i>[Signature]</i>	DATE <i>[Date]</i>
DRAWN <i>[Signature]</i>	DATE 4-11-67

SIZE B	CODE IDENT. NO. 82679	DWG NO. AX671	ISSUE Ø
SCALE 1:4	SHEET OF		