

AX 487

THE CONTENTS OF THIS DRAWING ARE THE EXCLUSIVE PROPERTY OF THE TECHNICAL MATERIEL CORP. ITS UNAUTHORIZED USE OR REPRODUCTION IN WHOLE OR IN PART IS STRICTLY FORBIDDEN.

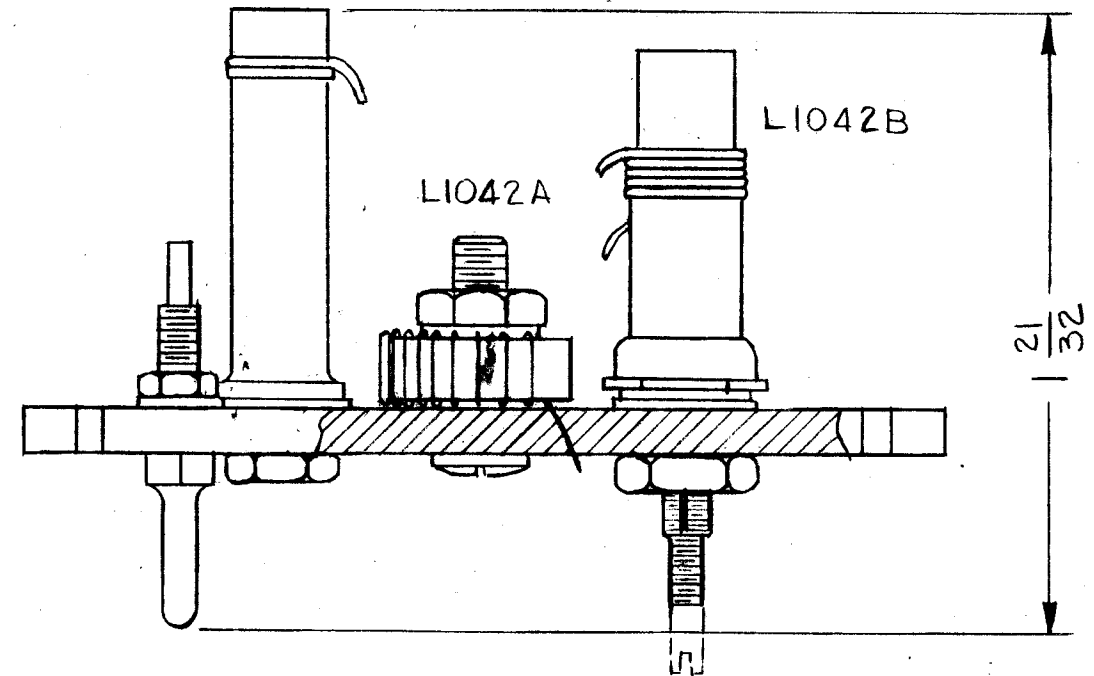
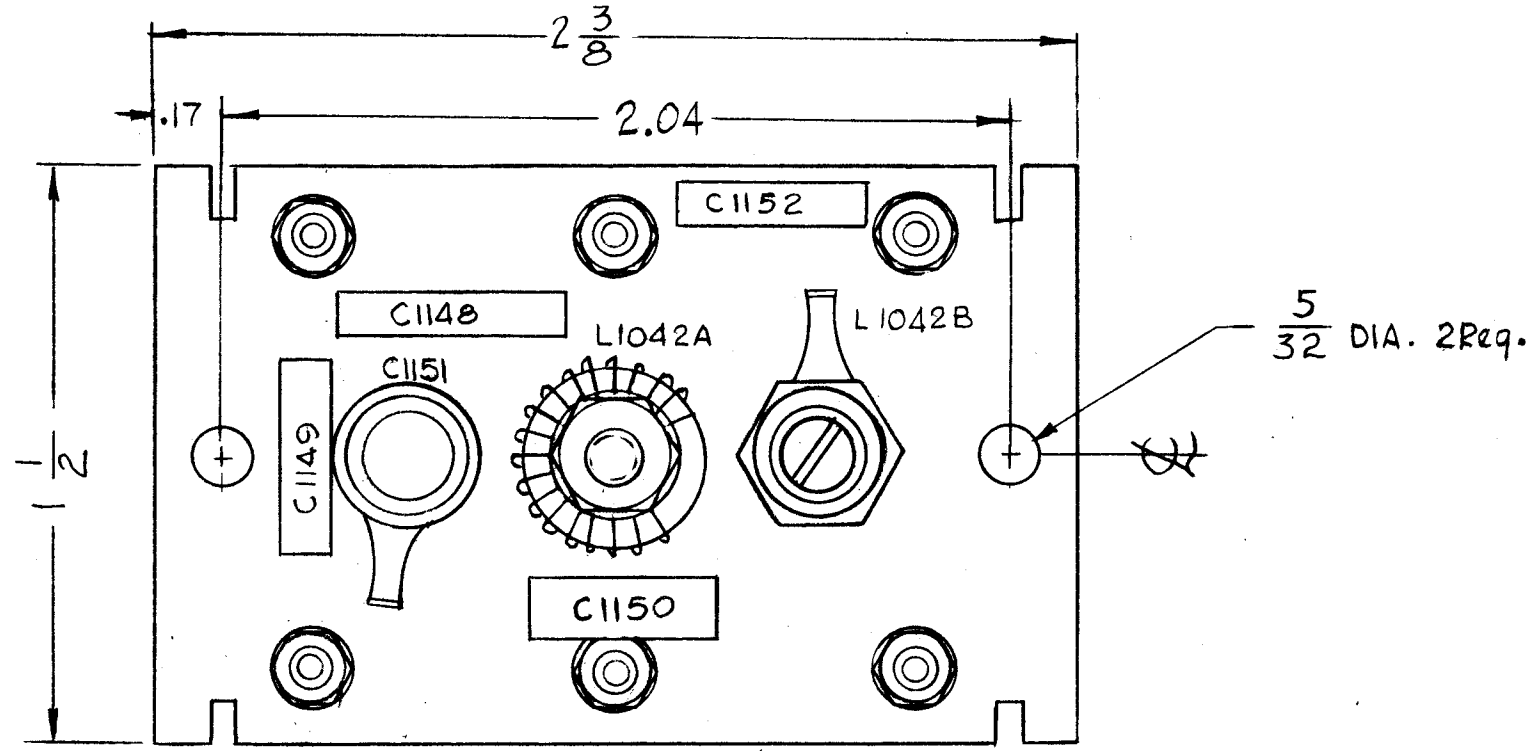

NOTICE TO PERSONS RECEIVING THIS DRAWING

THE TECHNICAL MATERIEL CORPORATION claims proprietary right in the material disclosed hereon. This drawing is issued in confidence for engineering information only and may not be reproduced or used to manufacture anything shown hereon without permission from THE TECHNICAL MATERIEL CORPORATION to the user. This drawing is loaned for mutual assistance and is subject to recall at any time.

Property of:
THE TECHNICAL MATERIEL CORPORATION
MAMARONECK, NEW YORK

<input type="checkbox"/>	ORIGINAL RELEASE FOR PRODUCTION	B-13-64				
<input checked="" type="checkbox"/>	EXPERIMENTAL RELEASE	3-26-64				
SYM	DESCRIPTION	DATE	CH. NO.	DRAFTS	CHECKER	ENG. APP.
UNLESS OTHERWISE SPECIFIED:		SCALE: 2:1				
DIMENSIONS ARE IN INCHES		MAXIMUM ALLOWABLE TOLERANCES HAVE BEEN DETERMINED AND ANY DEVIATIONS WILL BE CAUSE FOR REJECTION.				
TOLERANCES ON FRACTIONS $\pm 1/64$		DECIMALS $\pm .005$				
		ANGLES $\pm 1/20^\circ$				
		REMOVE ALL BURRS AND SHARP EDGES				

1	HFR-2		A 3502		
1	HFR-1A		A 3502	2-25-64	
REQ. PER UNIT	MODEL	SECTION	ASSY. NO.	DATE	
USED ON					

REQ.	ITEM	PART NO.	ANGER	DESCRIPTION	SYMBOL
			THE TECHNICAL MATERIEL CORP. MAMARONECK, NEW YORK		
			TERMINAL BOARD, OSC., ASSY		
			BAND #6		
			G.D.L	@	RDL
TYPE & TEMPER	HEAT TREAT. SPEC.	DRAWN	CHECKED	FINAL APPROVAL	
		Janger		AX 487	
FINISH & SPEC. NO.		ELEC. DES. APP.	MECH. DES. APP.		