

AX 482

REVISIONS					
SYM	DESCRIPTION	DATE	E.M.N. NO.	DRAFT	CHKD APPD
X	EXPERIMENTAL RELEASE	3/25/64		G.D.L.	
Ø	ORIGINAL RELEASE FOR PRODUCTION	8-13-64		G.D.L.	

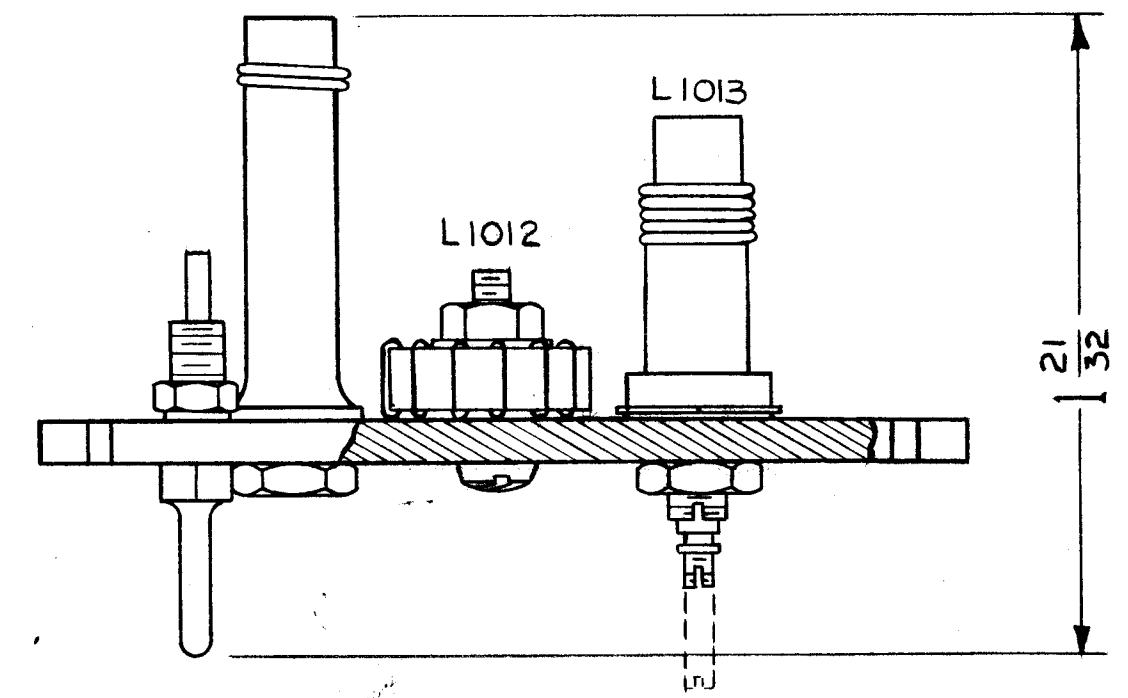
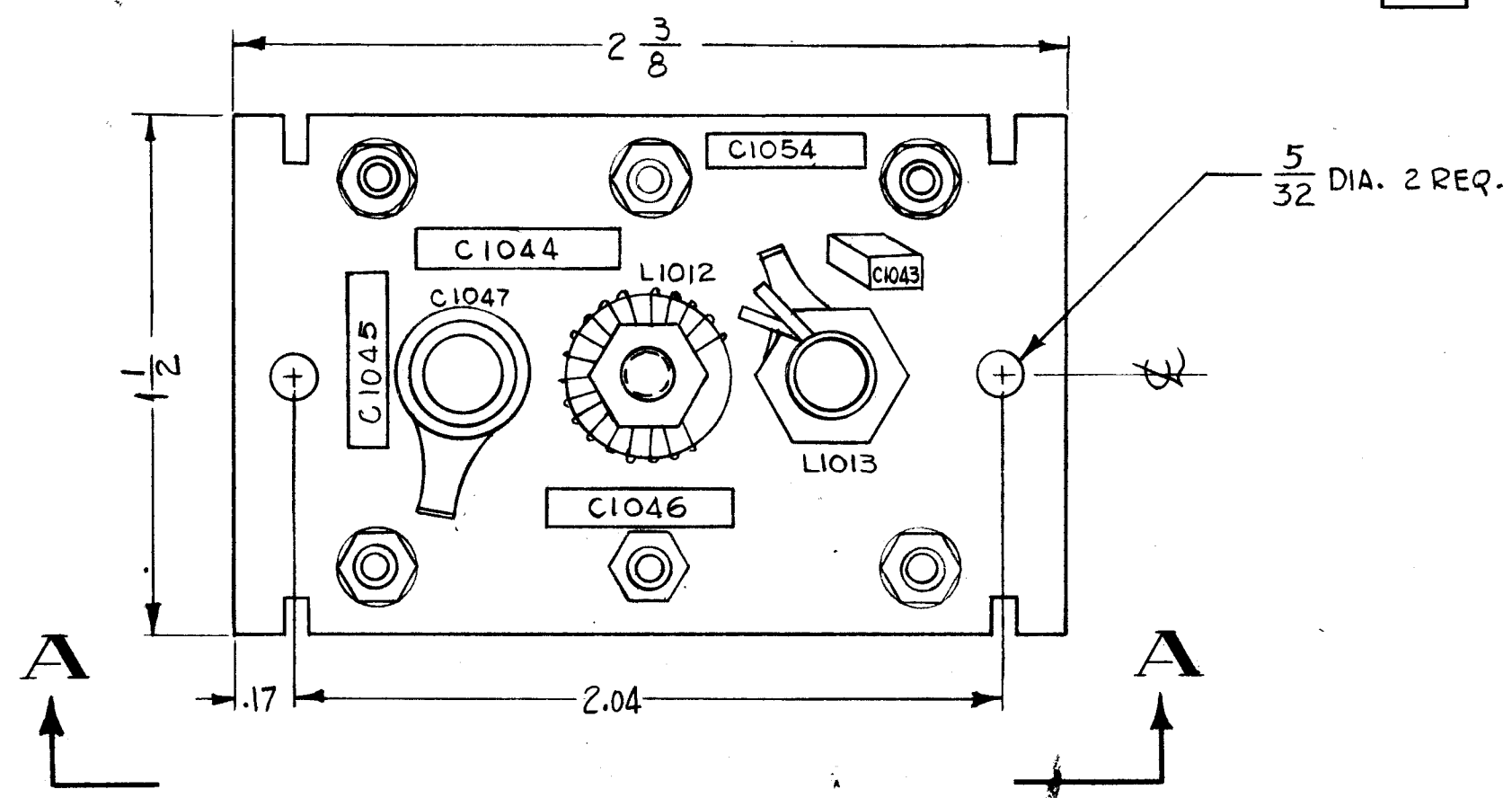

VIEW A-A

NOT CE TO PERSONS RECEIVING THIS DRAWING

THE TECHNICAL MATERIEL CORPORATION claims proprietary right in the material disclosed hereon. This drawing is issued in confidence for engineering information only and may not be reproduced or used to manufacture anything shown hereon without permission from THE TECHNICAL MATERIEL CORPORATION of the user. This drawing is loaned for mutual assistance and is subject to recall at any time.

Property of:  
THE TECHNICAL MATERIEL CORPORATION  
MAMARONECK, NEW YORK

1	HFR-2	A 3492
1	HFR-1A	A 3492
Q'TY./UNIT	MODEL USED ON	ASS'Y. NO.
SCALE	CODE	
2:1		
THE CONTENTS OF THIS DRAWING ARE THE EXCLUSIVE PROPERTY OF THE TECHNICAL MATERIEL CORP. ITS UNAUTHORIZED USE OR REPRODUCTION IN WHOLE OR IN PART IS STRICTLY FORBIDDEN.		

REQ'D.	ITEM	PART NUMBER	DESCRIPTION	SYMBOL
ANGER LIST OF MATERIAL				
MATERIAL			THE TECHNICAL MATERIEL CORP. MAMARONECK, NEW YORK	
FINISH			TITLE TERMINAL BOARD OSC., ASS'Y BAND #1	
UNLESS OTHERWISE SPECIFIED DIMENSIONS ARE IN INCHES AND INCLUDE CHEMICALLY APPLIED OR PLATED FINISHES			DRAWN G.D.L.	DATE 2-24-64
			CHECKED	DATE
			ELECT. DES. J. Anger	DATE 3/25/64
			MECH. DES.	DATE
DECIMALS .X ± .05 .XX ± .01 .XXX ± .005			FINAL APPROVAL KAL	
FRACTIONS ± 1/64 ANGLES ± 0° 30'			AX 482	
TOLERANCES			Ø	
			SHEET	
			REV. LTR.	

NOTES

109