

| | | | |
|---------------|-----------|---------|---|
| REQ. PER UNIT | USED ON | AX-223 | A |
| 2 | ASSY. NO. | | |
| | MODEL | | |
| | DATE | 4-11-60 | |
| | | 408-103 | |

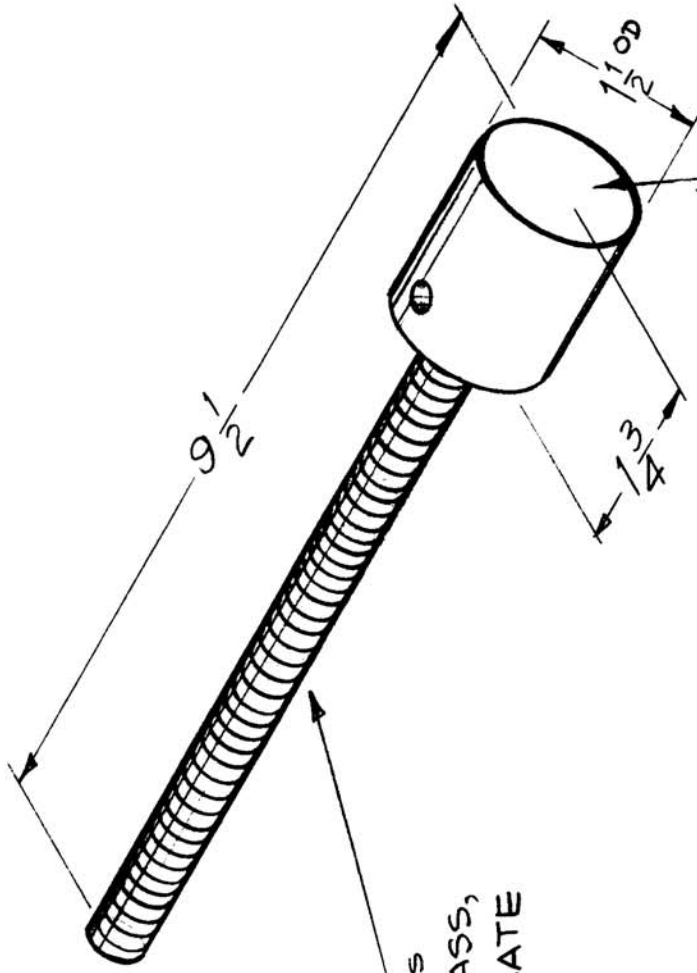

1/2-20Thds
ROD, BRASS,
SILVER PLATE

CONTACT, BRASS
RHODIUM PLATE

| REG. ITEM | PART NO. | DESCRIPTION | SYMBOL |
|-----------|--------------------|--|---------------------------------|
| | | THE TECHNICAL MATERIEL CORP. MAMARONECK, NEW YORK | |
| | | CONTACT ASSY., BAL. OUTPUT | |
| | | STOCK SIZE | |
| | | MATERIAL | |
| | | TYPE & TEMPER | DRAWN |
| | | HEAT TREAT. SPEC. | CHECKED |
| | | FINISH & SPEC. NO. | ELEC. DES. APP. MECH. DES. APP. |
| A 1 | ROD WAS GOLD PLATE | 11-14-63 | 10358 |
| | CHANGED FROM | DATE | CH. NO. |
| | | 11-14-63 | 10358 |
| | | DRAFTS | CHECKER |
| | | | ENG. APP. |
| | | SCALE: | 1A-1863 |
| | | MAXIMUM ALLOWABLE TOLERANCES HAVE BEEN DETERMINED AND ANY DEVIATIONS WILL BE CAUSE FOR REJECTION. REMOVE ALL BURRS AND SHARP EDGES | |
| | | TOLERANCES | |
| | | DEC. DIM. ± | |
| | | FRAC. DIM. ± | |
| | | ANGULAR DIM. ± | |
| | | | FINAL APPROVAL |
| | | | AX-223 |