

		REVISIONS					
ZONE	LTR	DESCRIPTION	DATE	E.M.N.NO	DRAFT	CHKD	APPD
	X	EXP. RELEASE	9/3/68	++	H.S.		
		ORIGINAL RELEASE FOR PRODUCTION	4/23/68		EG		

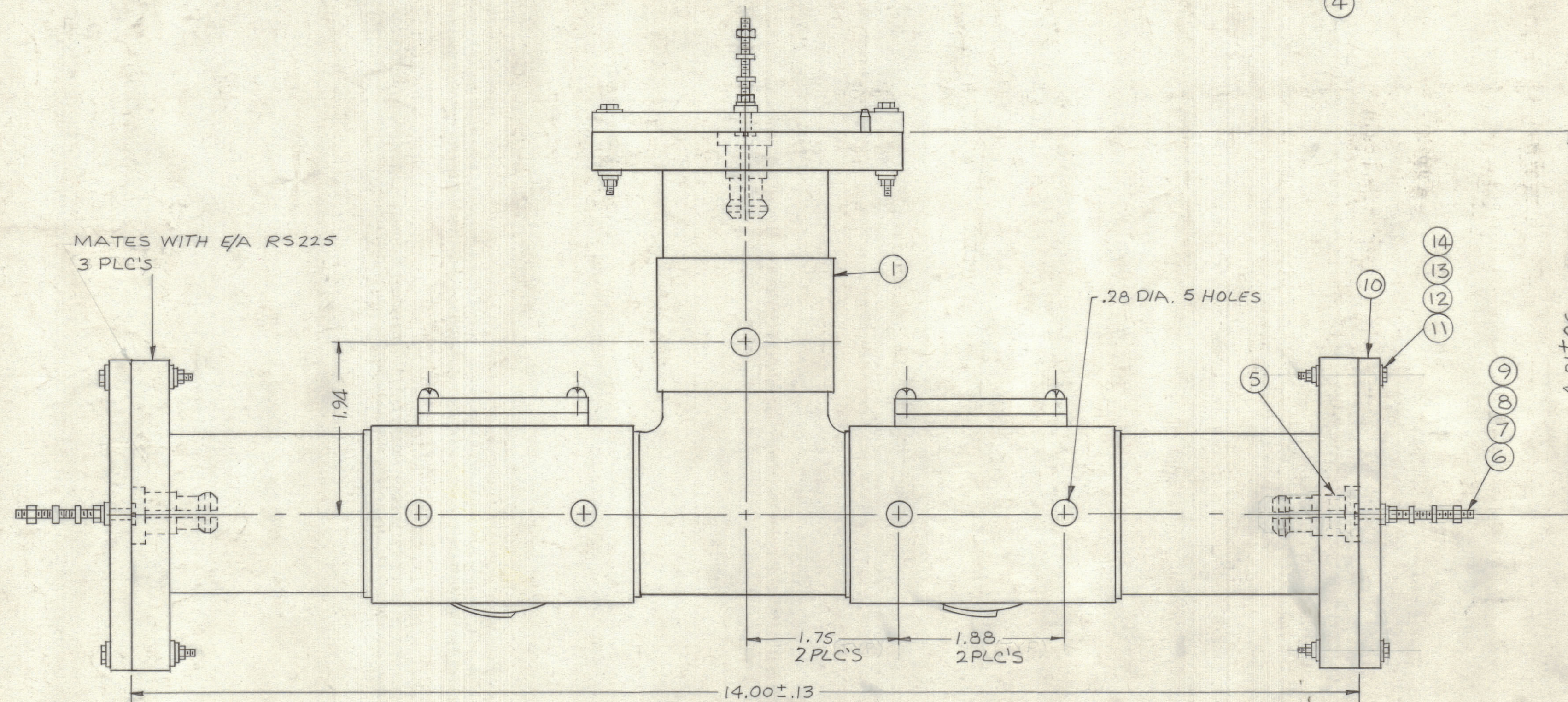
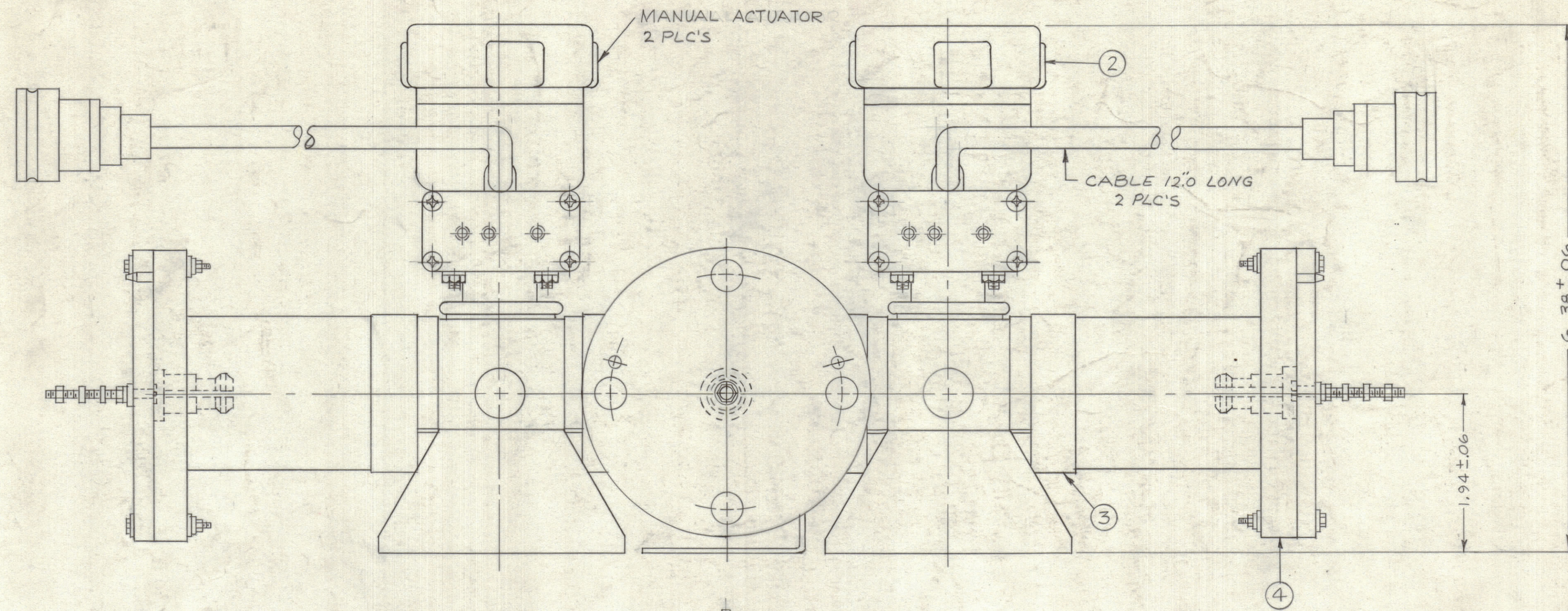

QTY.	REQ.	ITEM	PART NO.	DESCRIPTION	SYMBOL
12	14	SCHH2520BN16		SCREW, MACHINE	
12	13	NTH2520BN14		NUT, PLN, HEX	
12	12	LWS25MRN		WASHER, LOCK, SPLIT	
24	11	FW25HBN		WASHER, FLAT	
3	10	PX636		PLATE, INS.	
6	9	NTH1032BN12		NUT, PLN, HEX	
6	8	FW10HBN		WASHER, FLAT	
6	7	LWS10MBN		WASHER, LOCK, SPLIT	
3	6	SCBP1032BN20		SCREW, MACHINE	
3	5	PO224-50		INNER, CONN, STUB	
3	4	PO318		ADAPTOR, MATRIX TO LINE	
2	3	PO316		BRACKET, HANGER	
2	2	A4655		RL150 ASSY	
1	1	PO319		SPLIT TEE	

QTY.	REQ.	ITEM	PART NO.	DESCRIPTION	SYMBOL
LIST OF MATERIAL					

UNLESS OTHERWISE SPECIFIED DIMENSIONS ARE IN INCHES AND INCLUDE CHEMICALLY APPLIED OR PLATED FINISHES		FINAL APPROVAL <i>[Signature]</i>	DATE	THE TECHNICAL MATERIEL CORP. MAMARONECK, NEW YORK	
TOLERANCES ON		MECH. DES.	DATE		
DECIMALS .X ± .05 .XX ± .01 .XXX ± .005		ELECT. DES. <i>[Signature]</i>	DATE		
FRACTIONS ± 1/64 ANGLES ± 0°-30'		CHECKED <i>[Signature]</i>	DATE		
MATERIAL		DRAWN <i>[Signature]</i>	DATE	SWITCH ASSY, COAXIAL	
FINISH			DATE		
CODE A 5401-48		DATE 9/3/68		SIZE	CODE IDENT. NO.
NOTICE TO PERSONS RECEIVING THIS DRAWING THE TECHNICAL MATERIEL CORPORATION claims proprietary right in the material disclosed hereon. This drawing is issued in confidence for engineering information only and may not be reproduced or used to manufacture anything shown hereon without permission from THE TECHNICAL MATERIEL CORPORATION to the user. This drawing is loaned for mutual assistance and is subject to recall at any time.		DATE 9/3/68		D	82679
				DWG NO.	AS 142
				ISSUE	
				SCALE	1:1
				SHEET	OF

1	GPT-40KEL	
QTY / UNIT	MODEL USED ON	ASSY NO.
APPLICATION		
CODE	5401-48	
NOTICE TO PERSONS RECEIVING THIS DRAWING		
THE TECHNICAL MATERIEL CORPORATION claims proprietary right in the material disclosed hereon. This drawing is issued in confidence for engineering information only and may not be reproduced or used to manufacture anything shown hereon without permission from THE TECHNICAL MATERIEL CORPORATION to the user. This drawing is loaned for mutual assistance and is subject to recall at any time.		