

REQ. PER UNIT	1
MODEL	TSTE-10K
ASSY. NO.	AR176
DATE	3-29-66
AR175 $\emptyset$	

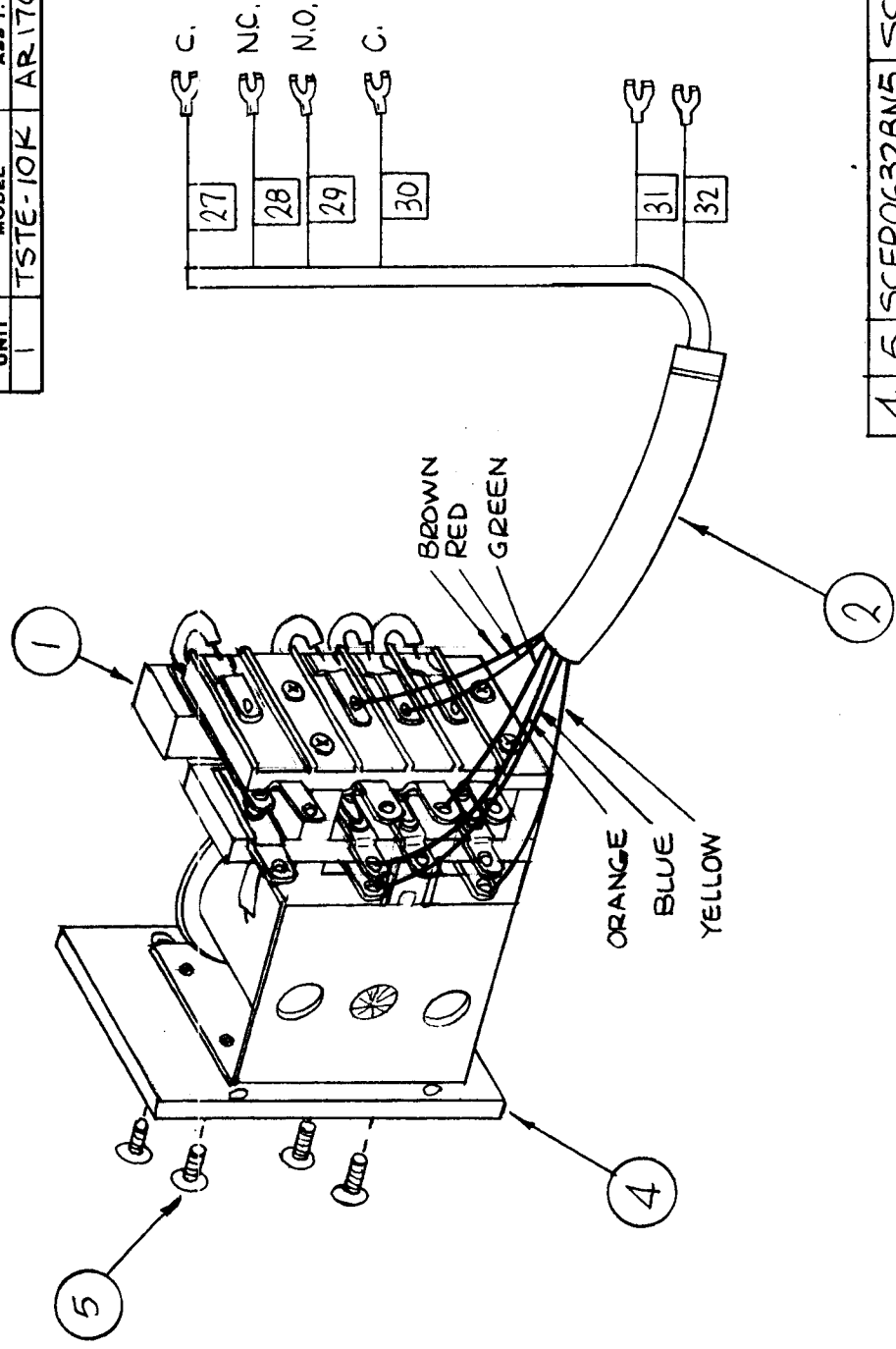

4	5	SCFP0632BN5	SCREW, MACHINE		
1	4	MS4596	PLATE, MTG RELAY		
X	3	BS100	SOLDER, TIN ALLOY		
1	2	CA1132	WIRING HARNESS, BRANCHED		
1	1	RL65-1A	RELAY, ARM.		
			F. BUDETTI	DESCRIPTION	SYMBOL
			THE TECHNICAL MATERIEL CORP. MAMARONECK, NEW YORK		
			RELAY ARM. ASSY		
			TYPE & TEMPER	HEAT TREAT. SPEC.	
			DRAWN	CHECKED	
			FINISH & SPEC. NO.		

DATE	3-29-66	CH. NO.	M	DRAFTS	Jc	CHECKER	Jc	ENG. APP.	
DATE	3-29-66	CH. NO.	X2	DRAFTS	RL	CHECKER	RL	ENG. APP.	
DESCRIPTION		SCALE							
UNLESS OTHERWISE SPECIFIED		DIMENSIONS ARE IN INCHES AND INCLUDE							
CHEMICALLY APPLIED OR PLATED FINISHES		FRACTIONS							
DECIMALS		TOLERANCES							
X ± .05		± 1/64							
XX ± .01		ANGLES							
XXX ± .005		± 0° 30'							
TOLERANCES		CODE							
C		C							
ORIGINAL RELEASE FOR PRODUCTION									
REDRAWN									