

AR-153 0

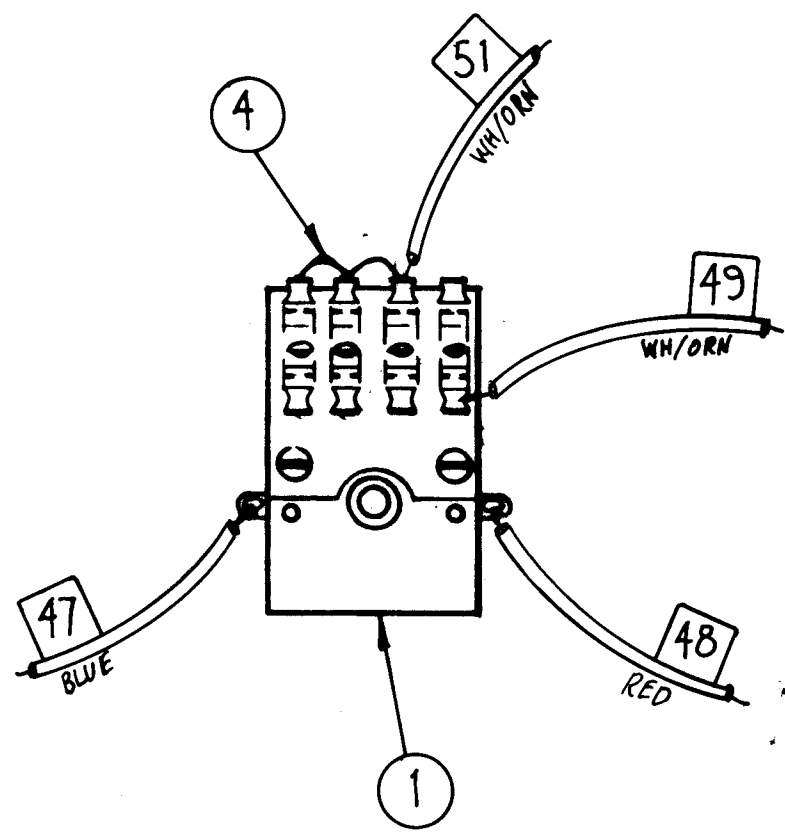
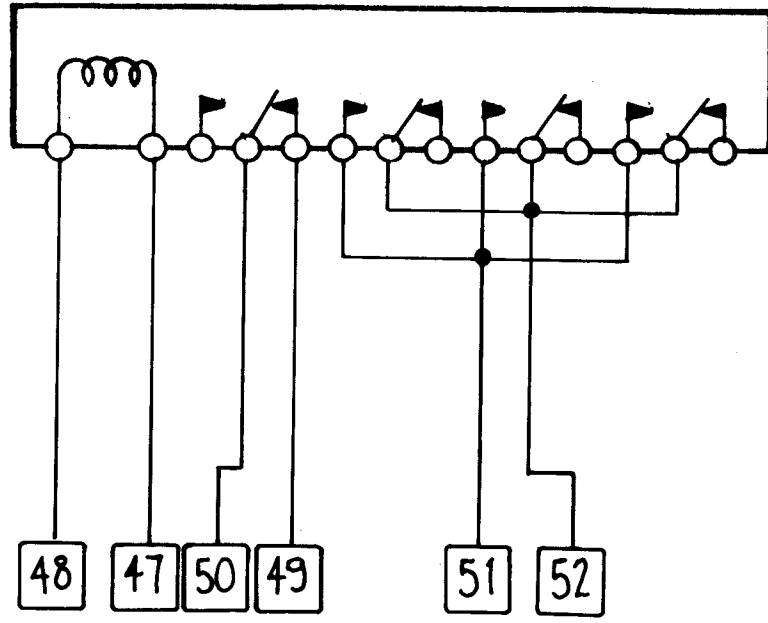
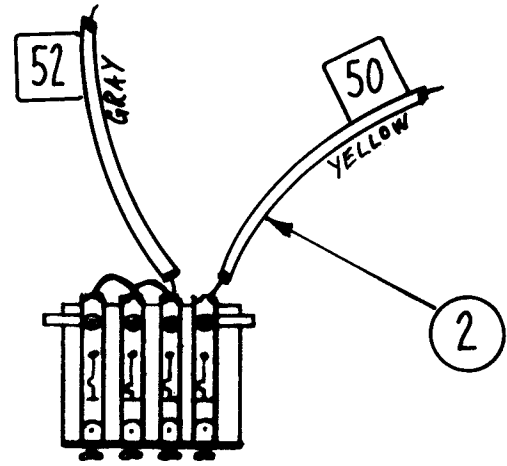

0	1	ORIG. RELEASE FOR PROD.	4-24-64					SAG
A	1	REDRAWN & REVISED						
ISSUE	ITE	CHANGED FROM	DATE	CH. NO.	DRAFTS	CHECKER	ENG. APP.	
TOLERANCES			SCALE:					
DEC. DIM. ±	CODE		MAXIMUM ALLOWABLE TOLERANCES HAVE BEEN DETERMINED AND ANY DEVIATIONS WILL BE CAUSE FOR REJECTION. REMOVE ALL BURRS AND SHARP EDGES					
FRAC. DIM. ±	A							
ANGULAR DIM. ±								

1	GPT-200K	AR-138		1-14-64
REQ. PER UNIT	MODEL	PROJECT NO.	ASS'Y. NO.	DATE
USED ON				

X	4	WL-100-6	WIRE, BUSS #20	
X	3	BS-100	SOLDER, SOFT	
1	2	CA-777	CABLE ASS'Y, BIAS RELAY	
1	1	RL-159	RELAY, ARMATURE	
REQ. ITEM	PART NO.	F. BUDETTI DESCRIPTION		SYMBOL
STOCK SIZE			THE TECHNICAL MATERIEL CORP. MAMARONECK, NEW YORK	
MATERIAL			RELAY ASS'Y, BIAS (RELAY "B")	
		W.A. FRANCO	aa	Rdx
TYPE & TEMPER		DRAWN	CHECKED	FINAL APPROVAL
				AR-153 0
FINISH & SPEC. NO.		ELC. DES. APP.	MECH. DES. APP.	