

MOUNTING DETAIL

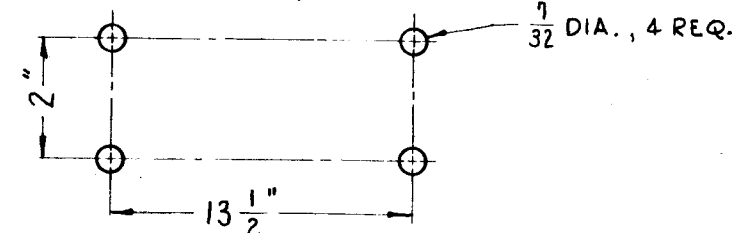

AF 103 C

REVISIONS					
SYM	DESCRIPTION	DATE	E.M.N. NO.	DRAFT	CHKD
A	CLAMP ADDED TO PICTORIAL	8-5-63	9665	AK.	AK
B	CLAMP ADDED TO PICTORIAL	4-6-64	11175	A.M.	AK
C	ADD. "BRACKET FASTENING ETC" NOTE	3-14-66	15949	HLA	AK

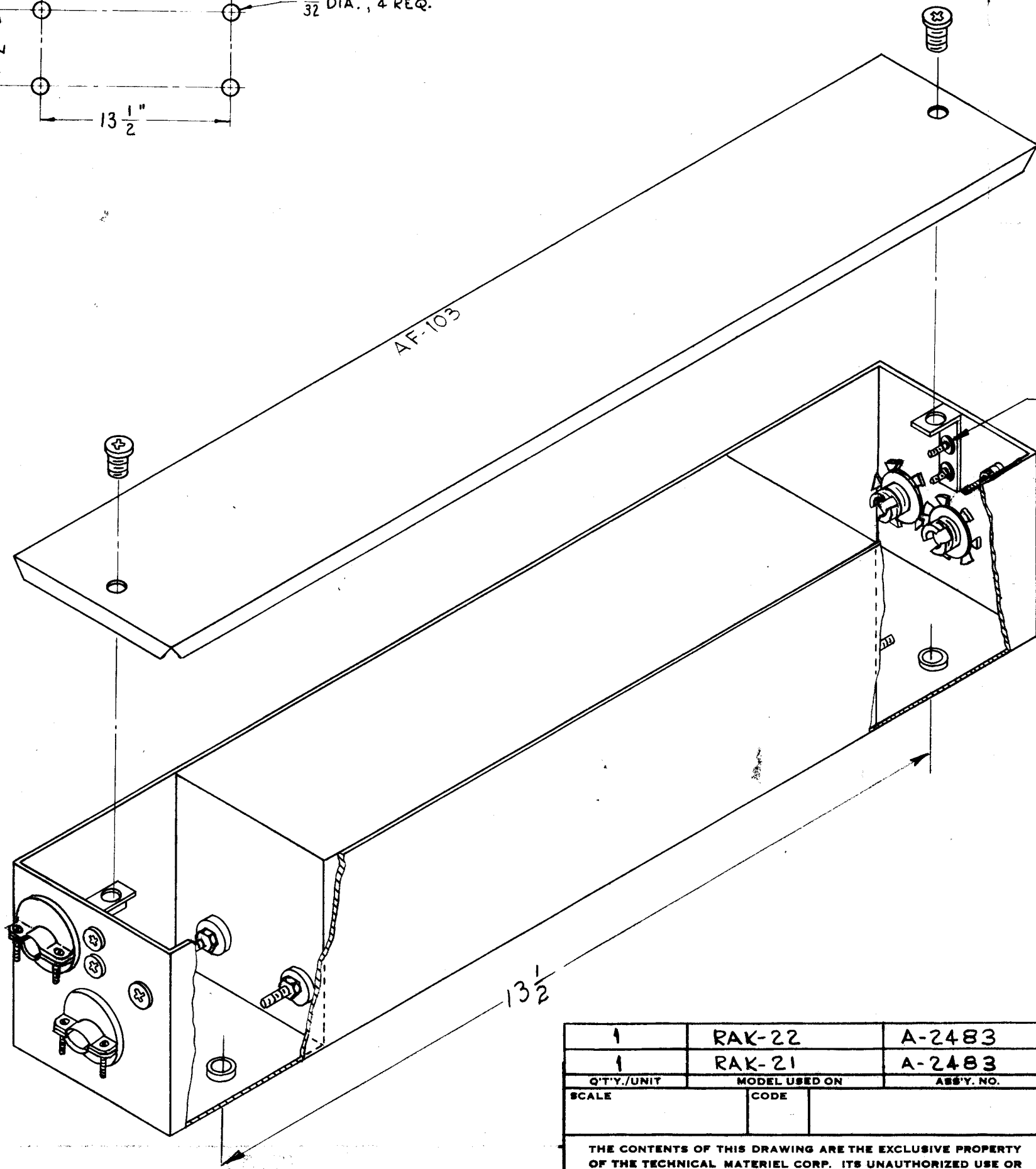

BRACKET FASTENING METHOD OPTIONAL

SPECIFICATIONS

POWER FREQ. - 0 THRU 400 CPS
 VOLTAGE - 250VAC/600VDC
 CURRENT - 20 AMPS MAX.
 ATTENUATION - 60 DB MIN., FROM 150KC THRU 10 KMC
 CASE MATERIAL - STEEL - 3" x 3" x 16-1/2" LONG
 TERMINALS - SCREW TYPE, 8-32 THDS.
 MOUNTING - (4) 8-32 SCREW

NOTE:
 1 - THE FILTER SECTION IS HERMETICALLY SEALED
 2 - COVER SUPPLIED WITH FILTER

Q'TY./UNIT	MODEL USED ON	ASS'Y. NO.
1	RAK-22	A-2483
1	RAK-21	A-2483
SCALE	CODE	

THE CONTENTS OF THIS DRAWING ARE THE EXCLUSIVE PROPERTY OF THE TECHNICAL MATERIEL CORP. ITS UNAUTHORIZED USE OR REPRODUCTION IN WHOLE OR IN PART IS STRICTLY FORBIDDEN.

REQ'D.	ITEM	PART NUMBER	DESCRIPTION	SYMBOL
R. KOHN LIST OF MATERIAL				
MATERIAL			THE TECHNICAL MATERIEL CORP. MAMARONECK, NEW YORK	
FINISH			TITLE FILTER, RADIO INTERFERENCE	
UNLESS OTHERWISE SPECIFIED DIMENSIONS ARE IN INCHES AND INCLUDE CHEMICALLY APPLIED OR PLATED FINISHES			DRAWN: <i>G. Soren</i> CHECKED: <i>Hille</i> ELECT. DES.: <i>R. KOHN</i> MECH. DES.: <i>R. KOHN</i>	DATE: 8-7-62 DATE: 8-16-62 DATE: 8AUG 62 DATE: 8AUG 62
DECIMALS .X ± .05 .XX ± .01 .XXX ± .005			FRACTIONS ± 1/64 ANGLES ± 0° 30'	TOLERANCES
			FINAL APPROVAL: <i>BP</i> DATE:	DATE:
			SHEET: AF 103	REV. LTR.: C